

DRAFT – DO NOT QUOTE OR CITE

ALTERNATIVE CONTROL TECHNIQUES DOCUMENT UPDATE –

NO_x EMISSIONS FROM NEW CEMENT KILNS

DRAFT

Sectors Policies and Programs Division

**U.S. Environmental Protection Agency
Office of Air and Radiation
Office of Air Quality Planning and Standards
Research Triangle Park, North Carolina 27711**

June 2007

TABLE OF CONTENTS

1.0	INTRODUCTION/PURPOSE.....	1
2.0	SUMMARY	2
2.1	Process Description.....	2
2.2	NO _x Emissions from PH/PC Kilns	2
2.3	Factors Affecting NO _x Emissions.....	2
2.4	Process controls that Reduce NO _x Emissions.....	3
2.5	Staged Combustion	4
2.6	Selective Noncatalytic Reduction (SNCR).....	4
2.7	Selective Catalytic Reduction.....	6
2.8	Multipollutant Effects	8
2.9	Costs – SNCR and SCR.....	8
3.0	PROCESS DESCRIPTION	9
3.1	Process Steps and Operations	9
3.2	New Kilns	10
3.2.1	Preheater	13
3.2.2	Calciner.....	14
3.2.3	Rotary Kiln.....	19
3.2.4	Alkali Bypass – PH/PC Kiln Systems	20
3.3	References.....	21
4.0	NO _x EMISSIONS FROM PH/PC KILNS	22
4.1	Thermal NO _x	22
4.2	Fuel NO _x	24
4.3	Feed NO _x	25
4.4	Prompt NO _x	25
4.5	References.....	25
5.0	FACTORS AFFECTING NO _x EMISSIONS	27
6.0	PROCESS CONTROLS THAT REDUCE NO _x EMISSIONS	29
6.1	Combustion Zone Control of Temperature and Excess Air.....	29
6.2	Feed Mix Composition	29
6.3	Kiln Fuel	30
6.4	Increasing Thermal Efficiency.....	30
6.5	Staged Combustion in Kiln.....	30
6.6	Efficient Cooler Control	30
6.7	Expert Control Systems	31
6.8	Low NO _x Burners (LNB) in Kiln.....	31
6.9	References.....	32
7.0	STAGED COMBUSTION	33
7.1	SCC Mechanism	33
7.2	Three types of SCC	35
7.2.1	Staged-Air.....	35
7.2.2	Air and Fuel Staging.....	36
7.2.3	Sequenced Fuel and Air	37

7.3	Summary of SCC NO _x Performance.....	38
7.4	Limitations of MSC – High Sulfur	40
7.5	References.....	40
8.0	SELECTIVE NONCATALYTIC REDUCTION (SNCR).....	42
8.1	Basis of SNCR	42
8.2	Equipment Needed for SNCR	42
8.3	Appropriate Temperature for SNCR.....	43
	8.3.1 Location of Suitable Temperature	44
8.4	Other Factors Affecting SNCR.....	45
	8.4.1 Residence Time.....	45
	8.4.2 Degree of Mixing	46
	8.4.3 Uncontrolled NO _x	46
	8.4.4 Normalized Stoichiometric Ratio (NSR).....	47
8.5	Potential Problems with SNCR.....	48
8.6	SNCR Experience	49
	8.6.1 United States – Early Tests	49
	8.6.2 U.S. Plants Presently Using or Installing SNCR	52
	8.6.3 SNCR – Foreign Experience – Europe, Japan, Taiwan	64
8.7	Summary of SNCR Performance.....	66
8.8	References.....	66
9.0	MULTISTAGE COMBUSTION (MSC) AND SELECTIVE NONCATALYTIC REDUCTION (SNCR)	72
9.1	References.....	75
10.0	SELECTIVE CATALYTIC REDUCTION (SCR)	77
10.1	Process Description.....	77
10.2	Equipment Needed for SCR.....	78
10.3	Early Pilot Tests.....	79
	10.3.1 USA.....	79
	10.3.2 Europe.....	80
10.4	SCR Installations	80
	10.4.1 Solnhofen – Germany	80
	10.4.2 Cementeria di Monselice – Italy.....	82
10.5	Issues/Solutions Using SCR at Cement Kilns – Saint Lawrence Cement Experience.....	83
	10.5.1 SO ₂ Oxidation	84
	10.5.2 High CaO Loading and Potential Masking – CaSO ₄ Formation	85
	10.5.3 Ammonium Bisulfate ⁷	85
	10.5.4 Water Soluble Alkali – Alkali Poisoning – Catalyst Deactivation	85
	10.5.5 The Solubility of Sodium and Potassium in the Fly Ash and the Form of Fly Ash Particles.....	86
	10.5.6 High-Dust Loadings.....	87
	10.5.7 NO _x Inlet Variability/NH ₃ Slip	88
	10.5.8 Catalyst Plugging/Fouling	88
	10.5.9 Temperature-Related Factors Leading to Lower SCR NO _x Removal Efficiencies.....	89

10.6	References.....	89
11.0	MULTIPOLLUTANT ASPECTS OF SELECTIVE NON-CATALYTIC REDUCTION (SNCR) AND SELECTIVE CATALYTIC REDUCTION (SCR)	91
11.1	References.....	92
12.0	SNCR AND SCR COSTS	93
12.1	References.....	103

APPENDIX A – BACT/RACT LAER DETERMINATIONS

LIST OF TABLES

Table	Page
2-1 Uncontrolled NO _x Emissions (pounds per ton [lb/t]) by Kiln Type	3
2-2 Summary of NO _x Performance of SCC.....	4
2-3 SNCR Summary.....	6
2-4 SCR Tests – Cementerie di Monselice	7
2-5 Cost Effectiveness and Cost Burden of SNCR and SCR Systems	8
3-1 Cement Kiln Capacities (mt/yr)	11
3-2 Operating Conditions – PH/PC Kilns	11
3-3 Heat Input by Cement Kiln Type.....	11
6-1 Uncontrolled NO _x Emissions (lb/t) – Cement Kilns.....	32
7-1 Parameters Affecting NO _x and Staged Combustion Responses	34
7-2 NO _x Emissions Performance of Selected Cement Plants	39
7-3 Summary of NO _x Performance of SCC	40
8-1 SuiTemperatures for SNCR	43
8-2 Summary of Pilot Test Results for Ash Grove and LaFarge	51
8-3 NO _x Reductions (%) for Lines at Holcim, Midlothian, Texas.....	54
8-4 BACT Determinations – Suwannee American Cement, Branford, Florida, 11/05	61
8-5 Emission Test Results with Tires – Florida Rock Industries, Newberry, Florida, 12/04	61
8-6 Emission Test Results without Tires – Florida Rock Industries, Newberry, Florida, 12/04.....	62
8-7 SNCR at a Taiwan Cement Plant.....	66
8-8 SNCR Summary.....	66
9-1 Effect of SNCR on Emissions with Staged Combustion.....	73
9-2 Impact of Injecting Ammonia in Burnout Zone	73
9-3 Impact of Injecting Ammonia in Reducing Zone	74
10-1 SCR Tests – 2006 – Cementerie di Monselice	83
11-1 Potential Multipollutant Effects of SNCR and SCR.....	91
12-1 SNCR and SCR Costs for Preheater/Precalciner Kilns	94
12-2 SNCR and SCR Costs for Preheater/Precalciner Kilns in 2005 Dollars	99

LIST OF FIGURES

Figure	Page
3-1 Primary operations – PH/PC kiln cement plant	9
3-2 Primary operations – PC/PH cement kiln plant	10
3-3 PH/PC kiln – Suwannee American Cement, Branford, Florida.....	12
3-4 PH/PC kiln system.	12
3-5 F.L. Schmidt ILC kiln system.....	16
3-6 F.L. Schmidt SLC with single-string preheater	17
3-7 F.L. Schmidt SLC with dual-string preheater	18
4-1 NO vs. temperature at various O ₂ levels.....	23
7-1 Principle of NO _x reduction by SCC	34
7-2 Suwannee American Cement, Branford, Florida, staged-air SCC.....	35
7-3 Suwannee American, Branford, Florida, Polysius MSC – SCC with kiln inlet burner	36
7-4 Florida Rock Industries, Newberry, Florida, air and fuel staging – SCC.....	36
7-5 Titan America, Medley, Florida, sequenced fuel and air – SCC	37
8-1 Ammonia and urea reduction at various temperatures	44
8-2 Possible SNCR injection points	45
8-3 NO _x reduction and residence time	46
8-4 Effect of initial NO _x level on reduction efficiency	47
8-5 Impact of Normalized Stoichiometric Ratio on NO _x reduction.....	48
8-6 Suwannee American Cement – Branford, Florida.....	57
8-7 SNCR injection location – Suwannee American Cement, Branford, Florida.....	58
8-8 Ammonia injection, Suwannee American Cement.....	58
8-9 Suwannee American Cement ammonia injection nozzle.....	59
9-1 NH ₃ injection – burnout zone.....	73
9-2 NH ₃ injection – reducing zone	74
10-1 SCR system adjacent to preheater tower at Solnhofer Portland cement plant.....	79

1.0 INTRODUCTION/PURPOSE

This report addresses nitrogen oxides (NO_x) controls for new cement kilns and focuses specifically on staged combustion in the calciner (SCC), selective noncatalytic reduction (SNCR), and selective catalytic reduction (SCR) as processes for the control of NO_x. Practices and controls that are incorporated in normal operating processes for cement kilns will also be discussed. Previous EPA documents on NO_x controls for cement kilns include *Alternative Control Techniques Document - NO_x Emissions from Cement Manufacturing*, dated March 1994 (EPA-453/R-94-004) and available online at www.epa.gov/ttn/catc/dir1/cement.pdf, and *NO_x Control Technologies for the Cement Industry*, dated September 19, 2000, and available online at www.epa.gov/ttn/naaqs/ozone/ozonetech/cement_nox_update_09152000.pdf.

This report summarizes information controls for new cement kilns; therefore, this document addresses only preheater/precalciner (PH/PC) cement kilns because these are the only type of kiln expected to be built in the future. For details on the other kiln types (e.g., wet kilns and long dry kilns) and their NO_x controls, please review the two EPA documents mentioned above.

This report is organized as follows:

Chapter 2	Summary
Chapter 3	Process Description
Chapter 4	NO _x Emissions from PH/PC Cement Kilns
Chapter 5	Factors Affecting NO _x Emissions
Chapter 6	Process Controls that Reduce NO _x Emissions
Chapter 7	Staged Combustion
Chapter 8	Selective Noncatalytic Reduction (SNCR)
Chapter 9	MSC and SNCR
Chapter 10	Selective Catalytic Reduction
Chapter 11	Multipollutant Aspects of SNCR and SCR
Chapter 12	SNCR and SCR Costs

Other technologies for lowering NO_x emissions have been considered for cement kilns; however, these technologies have not necessarily been demonstrated for any cement kiln. NO_x oxidation (LoTO_xTM) technology, for example, has been considered as a potentially applicable NO_x-lowering technology, although it is not currently demonstrated for cement kilns. Additional information on this and other technologies not discussed in this report can be found at the following Web sites:

- <http://seca.doe.gov/publications/proceedings/00/scr00/ANDERSON.PDF>
- http://www.tceq.state.tx.us/implementation/air/sip/BSA_settle.html
- <http://files.harc.edu/Projects/AirQuality/Projects/H028.DFW.2004/H28DFWExecutiveSummary.pdf>

2.0 SUMMARY

This section summarizes the information contained in this report. The reader is encouraged to read the complete chapters to obtain a more thorough understanding.

2.1 PROCESS DESCRIPTION

To produce cement clinker, raw materials are first quarried and crushed and then ground to a fine powder. The raw materials that contain the appropriate components needed to produce clinker are typically limestone, sand or silica, clays, mill scale, and fly ash. The major component of cement raw materials is limestone, which has a high concentration of calcium carbonate (CaCO_3). Once the raw materials have been inter-ground into powder form, the powder is stored in blending silos prior to its introduction into the kiln system. Blending renders the ground materials physically uniform and acceptable as feed to the kiln.

This report covers only preheater/precalciner (PH/PC) kilns, which have been available since 1970. All new cement kilns are this type primarily due to energy savings and greater throughput capacities compared to other kiln types. PH/PC kiln systems are so named because certain manufacturing processes (heating and calcination [driving off of the carbon dioxide] of the raw materials) take place in sections outside the rotary kiln proper (therefore, the prefix “pre” is used when describing the kiln type). The capacities of PH/PC kilns range from 450,000 to 1,580,000 metric tons per year (mt/yr) (495,000 to 1,740,000 tons per year [t/yr]), with an average of 869,000 mt/yr (956,000 t/yr). A diagram of a PH/PC system is shown in Section 3.2.

2.2 NO_x EMISSIONS FROM PH/PC KILNS

The high temperatures and oxidizing atmosphere required for cement manufacturing favor NO_x formation. In cement kilns, NO_x emissions are formed during fuel combustion by two primary mechanisms:

1. The oxidation of molecular nitrogen present in combustion air (thermal NO_x)
2. The oxidation of nitrogen compounds in fuel (fuel NO_x).

Sometimes, the raw material feed may also contain nitrogen compounds, which may lead to feed NO_x similar to fuel NO_x. Because of the high temperatures involved in burning or clinker formation, thermal NO_x is the dominant mechanism for NO_x formation in kiln systems.

2.3 FACTORS AFFECTING NO_x EMISSIONS

High temperatures are necessary for the required clinkering reactions to take place in the cement kiln. If a kiln's temperature drops too low, the clinker formation reactions will stop, and because these reactions are exothermic, the temperature will drop even further. The temperature must be raised by increasing the energy (fuel) input to the kiln. Once the clinkering formation reactions start again, the temperature will increase very rapidly, again requiring an adjustment of fuel input. These process variations, which result in temperature variations, are normal in cement kiln operations and can produce significant variations in NO_x emissions.

The kiln flame temperature is higher for gas burners than for coal burners; however, coal is the predominant fuel used in cement kilns. In addition to temperature variations that can initiate thermal NO_x formation, fuels with higher nitrogen content will have more nitrogen available for fuel NO_x formation. Changes in the feed rate, chemical composition, or moisture content of raw materials can also change a kiln’s operating parameters.

2.4 PROCESS CONTROLS THAT REDUCE NO_x EMISSIONS

The primary goal of process controls is to stabilize process parameters and kiln conditions. The process controls used to stabilize kiln operations also improve energy efficiency by reducing heat consumption, improve clinker quality, and increase the life of the cement plant. Another beneficial effect of process controls is the reduction of NO_x emissions because of improved fuel efficiency.

When determining uncontrolled NO_x emissions, the following standard operating practice (SOP) components should be considered. These SOPs are incorporated by all new PH/PC kiln systems.

- Combustion zone control of temperature and excess air through continuous monitoring of temperature and excess air
- Feed mix composition
- Kiln fuel type
- Increased thermal efficiency
- Staged combustion in kiln
- Efficient cooler control
- Expert control systems
- Low NO_x burners in the kiln.

As shown in Table 2-1, uncontrolled NO_x emissions from PH/PC cement kilns are lower than for other kiln types. PH/PC kilns have lower NO_x emission rates than other cement kiln types because they burn more fuel at the calcining temperature. They are also the most energy efficient kiln type. Uncontrolled emissions for the other kiln types are 55–155% higher than the PH/PC kiln system. Based on AP-42 emission factors for the various kiln types, these differences range from 14 to 76%.

Table 2-1. Uncontrolled NO_x Emissions (pounds per ton [lb/t]) by Kiln Type

Kiln Type	Range	Average/ Percent Higher than PH/PC Kiln	AP-42/ percent Higher than PH/PC Kiln
Wet	3.6–19.5	9.7 /155	7.4 /76
Long Dry	6.1–10.5	8.6 /126	6.0 /43
Preheater	2.5–11.7	5.9 /55	4.8 /14
PH/PC	0.9–7.0	3.8 /----	4.2 /----

2.5 STAGED COMBUSTION

There are many ways a PH/PC kiln system is considered to be using staged combustion (SC). The processes of the PH/PC kiln system itself, which include the drying, calcining, and sintering of the raw materials, can be considered SC. Also, a kiln with a multi-channel main kiln burner with indirect firing incorporates SC. All calciners have some degree of SC. The use of low NO_x calciners, which inject fuel near the kiln inlet, is a form of SC. Staged combustion as discussed in this report refers to SC in the calciner (SCC).

SCC works by staging the introduction of fuel, combustion air, and feed material in a manner to minimize NO_x formation and reduce NO_x to nitrogen. NO_x formed in the kiln's combustion zone is chemically reduced by maintaining a reducing atmosphere at the kiln feed end by firing fuel in this region. The reducing atmosphere is maintained in the calciner region by controlling combustion air such that the calcining fuel is first burned under reducing conditions to reduce NO_x and then burned under oxidizing conditions to complete the combustion reaction. Controlling the introduction of raw meal allows for control of the calciner temperature. Through these mechanisms, both fuel NO_x and thermal NO_x are controlled. The combustion chamber allows for improved control over the introduction of tertiary air in the calciner region, which helps to promote the proper reducing environment for NO_x control.

The performance of SCC at controlling NO_x is summarized in Table 2-2. Levels of NO_x from PH/PC kilns using SCC range from 1.0 to 4.8 lb NO_x/t of clinker, with an average of approximately 2.7 lb/t of clinker.

Table 2-2. Summary of NO_x Performance of SCC

Source/Location	NO _x Uncontrolled (lb/t)	NO _x Controlled (lb/t)	Efficiency
11 US kilns(from Table 7-2)	NA	2.2–3.3 (avg- 2.7)	NA
ECRA report	NA	2.4–4.8	NA
Florida Rock	3.5	3.0 -w/o tires;2.0-tires	17% -w/otires;43%-tires
Suwannee American	NA	2.4	NA
Titan American	NA	2.0	NA
Lone Star	2.8	1.8	35%
American Cement	NA	2.3–2.6 (reducing); 3.5–4.0 (oxidizing)	NA
European Report	NA	1.0–2.4	NA

2.6 SELECTIVE NONCATALYTIC REDUCTION (SNCR)

The SNCR process is basically the injection of ammonia in the form of ammonia water or urea in the flue-gas at a suitable temperature. An ammonia solution (~20%) is the reagent that has been most often used for cement kilns, and experience indicates that an ammonia solution is most effective for PH/PC cement kiln applications.

An SNCR system’s performance depends on temperature, residence time, turbulence, oxygen content, and a number of factors specific to the given gas stream. These factors are discussed later in this report. SNCR removes NO_x by a two-step process, as follows:

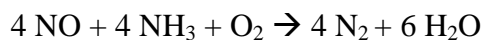

and

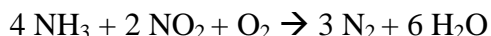

The first equation is the predominant reaction because 90–95% of NO_x in flue gas is NO.

Onsite storage vessels and a truck-unloading stand are required to receive the delivery of ammonia or urea to a plant. Ammonia and urea may be received as a liquid solution or may be mixed with water onsite to the desired solution concentration. If mixed onsite, additional water storage, purification, pumping, and mixing equipment is required. The purification system removes minerals from the water that may cause plugging of the ammonia delivery system. Ammonia, in the form of anhydrous ammonia gas, must be stored in cylinders. All forms of ammonia have specific transportation, handling, and storage requirements.

The ammonia solution is pumped through pipes and delivered into the precalciner or preheater tower through an injection lance. This injection process requires a pump, pump skid, and ammonia-flow control unit. The exact location and number of injection points will differ from one system to the next and is optimized through testing. Measurement equipment is necessary to maintain the appropriate ammonia feed rate. Additional monitoring equipment is required to record the amount of NO_x and ammonia slip in the gases exiting the SNCR system to adjust the amount of ammonia entering the system. Temperature monitors are also required to make sure that the ammonia is delivered to the correct location.

Important design and operational factors that affect NO_x reduction by an SNCR system are the following:

- Residence time available in optimum temperature range
- Degree of mixing between injected reagent and combustion gases
- Uncontrolled NO_x concentration level
- Molar ratio of injected reagent to uncontrolled NO_x.

Table 2-3 summarizes the performance of PH/PC cement kilns (except the Cemex plant, which has a preheater kiln) that have installed SNCR systems. Most SNCR systems use an ammonia solution. It appears that an emission level of 2.0 lb/t of clinker is achieved with an NSR of 0.5. At a higher NSR ratio of 1.0, NO_x could be reduced to around 1.0 lb/t of clinker. Uncontrolled NO_x (after SCC, LNB in the kiln and process controls) is 2.7 lb/t of clinker. On average, SNCR achieves a 35% reduction at an NSR of 0.5 and a 63% reduction at an NSR of 1.0. Ammonia slip may be a problem as the normalized stoichiometric ratio (NSR) is increased.

Table 2-3. SNCR Summary

Plant/Source	Control Level (lb/t)	Efficiency (%)	NSR
3 European kilns	NA	25–50; 35–60; 42–72	0.6; 0.8; 1.0
Ash Grove, Seattle	2.2; 1.3	25; 55	0.5; 1.0
Hercules, PA	300 ppm ~3.0	12–25	NA
Cemex; FL-preheater kiln	2.0	50	0.6–0.7
Suwannee American	2.0	33–50	NA
Florida Rock without tires	1.9; 2.6	47; 29	0.47; 0.35
Florida Rock with tires	2.1	34	0.12–0.25
Holcim – Texas (2 kilns)	NA	47, 32	0.7
European Report-achievable	1.0	80–85	NA
European Report - actual operation	2.5–4.0	10–50	0.5–0.9
Skovde, Sweden	0.5–1.0	80–85	1.0–1.1
Slite, Sweden	1.1	80	1.0
Taiwan-2 kilns	194ppm; 284 ppm ~2.0; 2.9	50; 46	NA

2.7 SELECTIVE CATALYTIC REDUCTION

SCR is the process of adding ammonia or urea in the presence of a catalyst to selectively reduce NO_x emissions from exhaust gases. The SCR process has been used extensively on gas turbines, internal combustion (IC) engines, and fossil fuel-fired utility boilers. In the SCR system, anhydrous ammonia, usually diluted with air or steam or aqueous ammonia solution, is injected through a catalyst bed to reduce NO_x emissions. A number of catalyst materials have been used, such as titanium dioxide, vanadium pentoxide, and zeolite-based materials. The catalyst is typically supported on ceramic materials (e.g., alumina in a honeycomb monolith form) and promotes the NO_x reduction reactions by providing a site for these reactions to occur. The catalyst is not consumed in the process, but allows the reactions to occur at a lower temperature.

The optimum temperature for the catalyst reactions depends on the specific catalyst used. Several different catalysts are available for use at different exhaust gas temperatures. Base metal catalysts are useful between 450 °F and 800 °F. For high temperature operations (675 °F to over 1100 °F), zeolite catalysts containing precious metals such as platinum and palladium are useful. The two principal reactions in the SCR process at cement plants using SCR are the following:

- $4 \text{NH}_3 + 4 \text{NO} + \text{O}_2 \rightarrow 4 \text{N}_2 + 6 \text{H}_2\text{O}$ (predominant reaction as most NO_x is NO)
- $4 \text{NH}_3 + 2 \text{NO}_2 + \text{O}_2 \rightarrow 3 \text{N}_2 + 6 \text{H}_2\text{O}$

In an SCR system, ammonia is typically injected to produce a NH₃: NO_x molar ratio of 1.05–1.1:1 to achieve a NO_x conversion of 80–90% with an ammonia slip of about 10 ppm of unreacted ammonia in gases leaving the reactor. The NO_x removal efficiency depends on the flue gas temperature, the molar ratio of ammonia to NO_x, and the flue gas residence time in the catalyst bed. All these factors must be considered in designing the desired NO_x reduction, the

appropriate reagent ratios, the catalyst bed volume, and the operating conditions. As with SNCR, the appropriate temperature window must be maintained to assure that ammonia slip does not result in a visible plume.

SCR can be installed at a cement kiln at two possible locations:

- After the PM control device – a “low-dust” system
- After the last cyclone without ducting – a “high-dust” system.

The advantages of a “low-dust” system are longer catalyst life and lower danger of blockage. The disadvantage is the additional energy costs required to heat the cooled exhaust to achieve proper reaction temperatures in the catalyst.

There are presently two cement kilns in the world that use selective catalytic reduction (SCR): Solnhofen in Germany and Cementeria di Monselice in Italy. Both kilns are preheater kilns. Both European cement kilns are “high-dust” SCR systems. A picture of the Solnhofen installation is shown in section 10.4.

Both plants use a 25% aqueous ammonia solution, have 6 catalyst layers but only use 3 layers. Both plants have similar designs and facilities that are similar in size and raw materials.

At Solnhofen, 200 mg/m³ (~ 0.8 lb/t) of NO_x is typically achieved from an inlet of 1,050 mg/Nm³ (4.2 lb/t) or 80% control. Also, ammonia slip was less than 1 mg/m³. Greater than 80% control is frequently achieved. At the end of 2003, the catalyst had logged 20,000–25,000 hours with no discernable problems. The catalyst was guaranteed for 16,000 hrs, with an expected catalyst life of 3–4 yrs.

The SCR system at Cementeria di Monselice in Bergamo, Italy began operation in June 2006. Catalyst activity remains high after 3,500 hours of operation. Following startup in June 2006, continuous testing was conducted for six weeks. The results of these tests are summarized in Table 2-4. As shown here, NO_x reduction was 95 % at molar ratio of 0.89 and 43 % at molar ratio of 0.2.

Table 2-4. SCR Tests – Cementerie di Monselice

Parameter	Units	Design	Actual*
Kiln capacity	t/day	2,400	1,800
Gas flow	m ³ /h norm; wet	160,000	110,000
NO _x inlet	mg/dscm	2,260	1,530/1,070
Molar ratio	NH ₃ /NO _x	0.905	0.89/0.2
NO _x outlet	mg/dscm @ actual O ₂	232	75/612
NO _x removal	percent	90	95/43
NH ₃ slip	mg/dscm	< 5	< 1/< 1
NH ₄ OH	25 percent solution; kg/h	445	204/34

* Two separate sets of data were collected for most parameters.

2.8 MULTIPOLLUTANT EFFECTS

The impacts of using SNCR and SCR controls on other pollutants can depend on the specific installation, including the nature of raw materials, kiln design and operating conditions. In general, for SNCR, emissions of NH₃, N₂O, CO, CO₂, and PM₁₀ may increase. For SCR, PM₁₀ emissions may increase. Ammonia emissions may increase but not as much as for SNCR. For SCR, emissions of CO, H₂SO₄, Hg, VOC and dioxin/furan may decrease.

2.9 COSTS – SNCR AND SCR

Costs for SNCR and SCR controls on PH/PC kilns were obtained from a variety of sources at cement kilns in the U.S. and Europe. Some costs represent the cost of retrofitting existing kilns. To compare the cost information, the costs were scaled to 2005.

Capital costs for SNCR systems primarily include the cost of an injection system for the ammonia-based or urea-based reagent, the delivery system, reagent storage tanks, and control instrumentation. Operating costs include the costs of reagents and additives, electricity for reagent pumping, and fuel penalty cost, along with operating labor and maintenance requirements. The primary annual cost component is ammonia. Cost effectiveness and cost burden for SNCR systems are summarized in Table 2-5.

SCR systems applied to cement PH/PC kilns can be either “low-dust” or “high-dust” systems depending on their location after or before the particulate matter control device. In both systems, capital costs include the cost of the SCR catalyst and reactor and, like the SNCR system, the reagent delivery system, storage, and instrumentation. Because of the problems of catalyst plugging, the high-dust system requires a catalyst cleaning mechanism, such as pressurized air nozzles or sonic horns. The low-dust system avoids costs associated with catalyst cleaning. Similar to SNCR, operating costs include operating labor and maintenance costs, reagent costs, and the electricity of reagent pumping. High-dust SCR systems incur higher energy costs for catalyst cleaning. Operating cost also include catalyst replacement every few years. Cost effectiveness and cost burden for SCR systems are summarized in Table 2-5.

Table 2-5. Cost Effectiveness and Cost Burden of SNCR and SCR Systems

Measure of Cost	SNCR System	SCR System
Cost Effectiveness (\$/t NO _x)		
Range	327 to 5,222	1,300 to 22,000
Mean	1,900	5,200
Median	1,400	2,000
Cost Burden (\$/t of clinker)		
Range	0.51 to 2.52	0.92 to 9.11
Mean	1.03	2.82
Median	0.93	1.81

3.0 PROCESS DESCRIPTION

3.1 PROCESS STEPS AND OPERATIONS

To produce cement clinker, raw materials that contain oxides of calcium, silica, aluminum, and iron are first quarried and crushed and then inter-ground to a fine powder. The raw materials that contain the appropriate components needed to produce clinker are typically limestone, sand or silica, clays, mill scale, and fly ash. The major component of cement raw materials is limestone, which has a high concentration of calcium carbonate (CaCO_3). This list only illustrates those raw materials that contain the compounds needed to produce clinker; however, almost any raw material in sufficient supply that contains one of the oxides mentioned above has the potential to be used in the cement manufacturing process. Once the raw materials have been inter-ground into powder form, the powder is stored in blending silos prior to its introduction into the kiln system. Blending renders the ground materials chemically uniform and acceptable as feed to the kiln (this raw material blend is typically called kiln feed or raw meal). Frequent analyses and quality control measures are necessary to ensure that raw materials are correctly proportioned during the manufacturing process because chemical uniformity of the feed to the kiln system is very important for stable kiln process operation.

Figure 3-1 depicts the primary operations of a typical PC/PH kiln system cement plant and the steps involved in producing cement. The initial step of quarrying and solid-fuel grinding is not shown in this figure. Figure 3-2 is a general flow diagram of a PH/PC kiln cement plant. Not all processes shown in the flow charts in Figure 3-2 will take place at all PH/PC plants; instead, the figure demonstrates all of the various processes that may be found at a typical new plant.

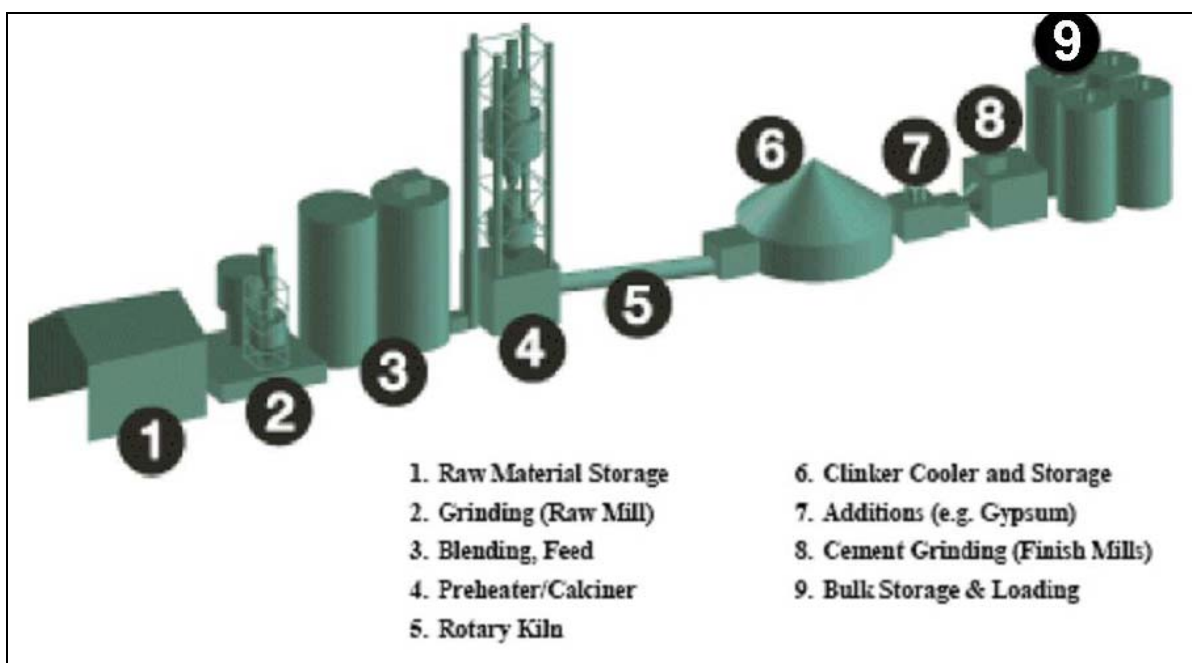

Figure 3-1. Primary operations – PH/PC kiln cement plant.¹

More details on the overall cement production operations are provided in the two EPA documents mentioned in Section 1. An excellent virtual tour of a cement plant is available at the Portland Cement Association Web site (www.cement.org/basics/images/flashtour.html).

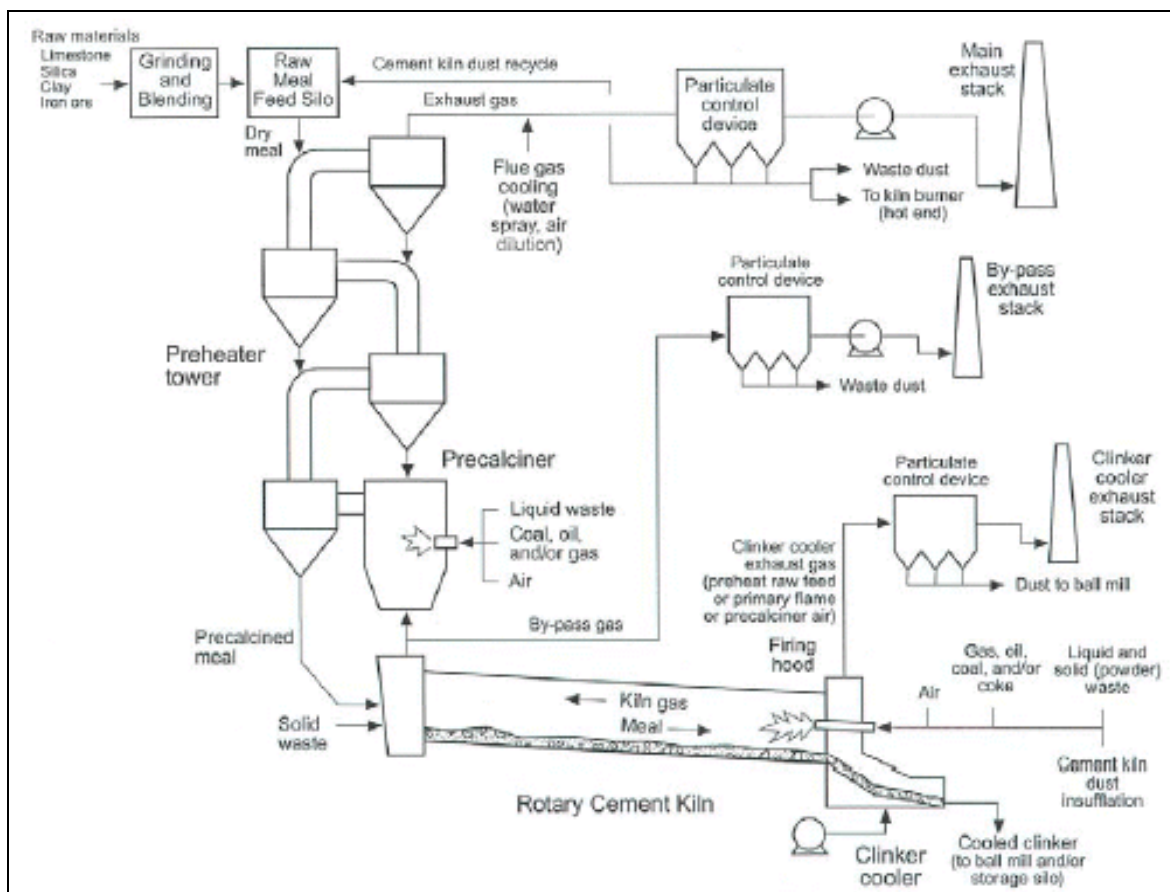

Figure 3-2. Primary operations – PC/PH cement kiln plant.²

3.2 NEW KILNS

This report covers only PH/PC kilns, which have been available since 1970. PH/PC kiln systems are so named because certain manufacturing processes (heating and calcination [driving off of the carbon dioxide] of the raw materials) take place in sections outside the rotary kiln proper (therefore, the prefix “pre” is used when describing the kiln type). The main reason why all new U.S. cement kiln systems are PH/PC kilns is because this kiln type has higher production capacities and greater fuel efficiency compared to other types of cement kilns. As shown in Table 3-1, the capacities of PH/PC kilns range from 450,000 to 1,580,000 mt/yr (495,000 to 1,740,000 t/yr), with an average of 869,000 mt/yr (956,000 t/yr).

Table 3-1. Cement Kiln Capacities (mt/yr)³

Kiln Type	Range	Average
Long wet	77,000 –1,180,000	307,000
Long dry	50,000 –590,000	265,000
Preheater	223,000 –1,237,000	406,000
PH/PC	450,000 –1,580,000	869,000

There are three distinct sections of the PH/PC kiln system, and the manufacturing processes that occur within these sections calcine most of the carbon dioxide (CO₂) from the raw materials before they enter the kiln. The first section, the preheater, is a tower that consists of a series of cyclones and interconnecting ducts that dry and preheat the blended raw materials. The raw materials are then moved to the second section, the bottom of the preheater tower, to a special furnace called the calciner, which calcines the CO₂ from the raw materials. Finally, the chemical reactions necessary to produce cement clinker in a PH/PC kiln cement plant occur in the section called the rotary kiln. A summary of the temperature profile ranges for the preheater, calciner, and rotary kiln of a PH/PC kiln plant, as well as the material retention time in these sections, is shown in Table 3-2.

Table 3-2. Operating Conditions – PH/PC Kilns^{4,5}

Parameter	Preheater	Calciner	Rotary Kiln
Gas temperature (°C)	350 – 950	850 – 1,200	1,200 – 2,000
Material temperature (°C)	200 – 750	800 – 900	1,200 –1,550
Material retention time	2 minutes	2 – 4 seconds	30 minutes

Fuel is fired in two places in the PH/PC kiln system: the calciner and the discharge end of the rotary kiln. In other cement kiln systems, all thermal processes occur within the kiln. As a result, conventional kilns are much longer than PH/PC kilns as well as much less fuel efficient than PH/PC kiln types. Table 3-3 shows heat inputs in terms of million British Thermal Units (mmBtu)/t of clinker for various types of kilns. As the data clearly demonstrates, PH/PC kilns provide greater fuel efficiency.

Table 3-3. Heat Input by Cement Kiln Type⁶

Kiln Type	Heat Input (mmBtu/t of clinker)	Percent Increase in Heat Input Compared to PH/PC Heat Input
Long wet	6.0	45
Long dry	4.5	36
Preheater	3.8	15
PH/PC	3.3	-----

A diagram and photo of a PH/PC kiln system are shown in Figures 3-3 and 3-4.

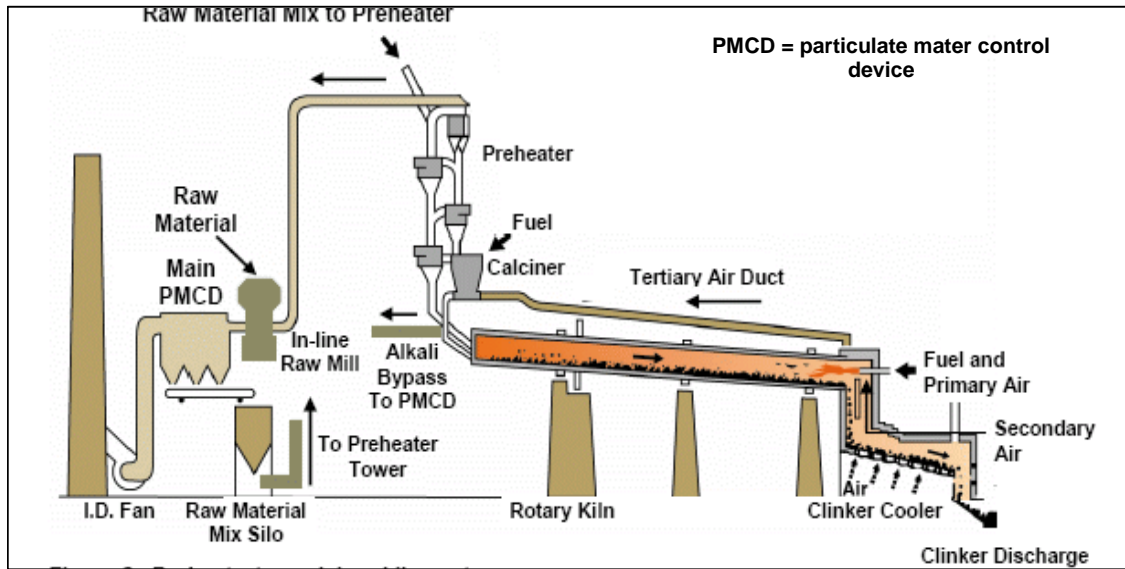

Figure 3-3. PH/PC kiln – Suwannee American Cement, Branford, Florida.



Figure 3-4. PH/PC kiln system.

The following reactions occur in the preheater, calciner, and rotary kiln of a PH/ PC kiln system:

- Evaporation of water in the upper stage of the preheater and heating of the raw meal from 100–400 °C (212–750 °F).
- Release of combined water from clay-like substances. This reaction takes place in temperature range between 400–650 °C (750–1,200 °F)
- Dissociation of magnesium carbonate (MgCO_3) into magnesium oxide and CO_2 from 650–750 °C (1,200–1,380 °F)
- Dissociation of CaCO_3 into lime (CaO) and CO_2 . This process is called calcination. About 90–95% of kiln feed is calcined prior to entering the kiln. This reaction takes place in the calciner, requires the addition of fuel, and occurs in the temperature range between 750–900 °C (1,380–1,650 °F). In addition, any carbonaceous material present in the raw meal is oxidized at this stage.
- Final calcination occurs in the rotary kiln, where the material is slowly heated from about 900–1,500 °C (1,650–2,750 °F) as it moves through the kiln. Reactions between CaO and other oxides occur in the rotary kiln to produce clinker, the final end product of the kiln cement process. Clinker typically contains 66% CaO , 21% silicon dioxide (SiO_2), 5% aluminum oxide (Al_2O_3), 3% ferric oxide (Fe_2O_3), and 5% other components.

The following subsections further describe the processes that occur in the preheater, calciner, and rotary kiln of a PH/PC kiln system, as well as information on a kiln bypass system.

3.2.1 Preheater

As previously stated, the major functions of the preheater are to drive off moisture and elevate the temperature of the kiln feed. All surface and inherent moisture is removed from the feed in the preheater tower. The feed is partially (40–50%) calcined ($\text{CaCO}_3 \rightarrow \text{CaO} + \text{CO}_2$) by the time it leaves the preheater.

The PH/PC kiln system uses an induced draft (ID) fan, which draws hot kiln gas through the kiln and preheater tower counter current to the material flow. Unheated raw meal is injected into the gas flow in the duct between the upper two cyclone stages of the preheater. This raw material is suspended in the hot gas stream and pulled by the ID fan to the first-stage cyclone, where the material is centrifugally separated from the gas stream. Because the feed is suspended in the hot gas stream, there is rapid heat transfer between the gases and the raw material. As the gas stream enters the preheater tower, the material travels by gravity from the first-stage cyclone via a duct between the second- and third-stage cyclones. The lower cyclones of the preheater are typically 80% efficient, meaning about 80% of the solid phase (raw material) is centrifugally separated from the gas and supplied to the cyclone stage beneath. The gas phase containing the remaining solids flows directly to the cyclone stage above. Usually, smaller double cyclones are used in the upper-most cyclone stage on each string, giving a higher cyclone efficiency, typically 95%.⁷

After the material-laden stream is transported to the second-stage cyclone, the material is again separated by centrifuge from the gas. After flowing down the cyclone tower, the meal is dried, and the clay minerals dehydrate and decompose. In addition, any organic compounds present in the raw materials are oxidized, and the MgCO_3 is calcined. The temperature in the preheater is typically increased to about $700\text{ }^\circ\text{C}$ ($1,290\text{ }^\circ\text{F}$), whereas the temperature of the counter-flowing gas is reduced from about $900\text{ }^\circ\text{C}$ ($1,650\text{ }^\circ\text{F}$) to about $350\text{ }^\circ\text{C}$ ($660\text{ }^\circ\text{F}$).

3.2.2 Calcliner

Upon leaving the preheater, the process material moves to the calciner, a vertical vessel attached to the preheater. The calciner utilizes combustion air drawn from the clinker cooler or kiln exit gases (known as tertiary air). In addition, about 60% of the fuel consumption of the PH/PC kiln system takes place in the calciner. The most-often used fuel is coal; however, almost any fuel can be used, including chipped tires, solid and liquid waste, gas, and oil. Fuel burned in calciner does not need to be of as high a quality as fuel burned in the front end of the rotary kiln. Because the combustion in the calciner occurs at $750\text{--}900\text{ }^\circ\text{C}$ ($1,380\text{--}1,650\text{ }^\circ\text{F}$), a fuel with a low Btu content is quite capable of delivering enough energy to calcine the limestone. The calcination process begins at about $815\text{ }^\circ\text{C}$ ($1,500\text{ }^\circ\text{F}$) and is completed at about $950\text{ }^\circ\text{C}$ ($1,750\text{ }^\circ\text{F}$).⁸ The process material is 90–95% calcined by the time the material leaves the calciner. If all the kiln feed is calcined, the heat-adsorbing endothermic reaction will end, and the material's temperature will rapidly increase. Such an increase can cause the lower melting components in the raw material to liquefy and condense on cooler sections of the preheater tower. Such buildups in the vessels and ducting of the system can cause significant operational problems and are avoided by limiting the degree to which the feed material is calcined. After removing CO_2 from the CaCO_3 , CaO is the remaining component. By removing 90–95% of CO_2 during the calcining process, the weight of the material is reduced by 32–34%. The overall reaction in the calciner can be summarized as follows:

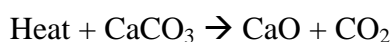

As the process material exits the calciner, the material and gas stream is swept to a final cyclone, whereupon the calcined material is centrifugally separated from the gas stream and the calcined feed enters the rotary kiln.⁷ Gas temperatures in calciner vessels are about $870\text{--}1,540\text{ }^\circ\text{C}$ ($1,600\text{--}1,800\text{ }^\circ\text{F}$). As mentioned above, tertiary air is the combustion air ducted to the calciner from the clinker cooler. Secondary air is the hot air recovered from clinker cooler and diverted to the kiln, and primary air is air entering the burner.²

In a PH/PC kiln without a bypass to control alkalis, sulfur, and/or chlorides, approximately 60% of the fuel is burned in the calciner. As the percent of bypass increases (i.e., heat is lost), the total amount of fuel required to achieve combustion in the calciner must also be increased to make up for the heat lost in the bypass gases.⁸

3.2.2.1 Types of Calcliners³

There are two main types of calciners: in-line calciners (ILCs) and separate-line calciners (SLCs). New systems use both designs with relatively equal frequency. Many advances in

technology have resulted in the development of specially designed calciners to meet such specific situations as variable raw material chemistry and a range of fuels to be used.

3.2.2.1.1 In-Line Calciners (ILCs)

An ILC is a calciner in which the tertiary air and kiln exhaust gas pass through the firing region of the calciner. This type of calciner is commonly used for normal fuels, such as coal, oil, gas, and wastes, with relatively high volatile bituminous coal serving as the dominant fuel. An ILC uses the hot recovered air from the cooler for fuel combustion. Since kiln combustion gases (O₂ content of approximately 2%) are mixed with the air from the cooler, the oxygen content of the ILC is much less than 21%, and the temperature is normally below 900 °C (1,650 °F). The low-oxygen content and temperature makes the ILC more compatible with fuels that have relatively high volatile content. Fuels with low volatile content, such as petroleum coke, are difficult to burn in the ILC system.

Figure 3-5 shows an ILC unit with an excess air, single-string cyclone preheater kiln with a small calciner built into kiln riser duct. Combustion air for the calciner is drawn through the kiln.²

3.2.2.1.2 Separate-Line Calciners (SLCs)³

In SLCs, the kiln exhaust gas bypasses the firing region of the calciner. An SLC uses air containing 21% oxygen recovered from the cooler for combustion, and this air is not mixed with kiln combustion gases. SLCs usually have longer gas-retention times and higher temperatures, allowing these systems to use low-volatile fuels, such as petroleum coke and anthracite. Existing systems are easier to upgrade with SLCs because there are many configurations for this type of calciner. Some SLCs contain only a single string, and some SLCs have a two-string preheater tower, with the kiln gas passing through one string of the preheater and the tertiary air entering the calciner through a separate (second) string of the preheater.

Figures 3-6 and 3-7 shows two types of SLCs. The SLC shown in Figure 3-6 is a down-draft unit, with a single-string cyclone preheater and a combustion chamber/calciner placed in parallel to the riser duct. Thus, combustion takes place using heated atmospheric air drawn from the cooler through a separate tertiary air duct, and the exhaust gas from the kiln and the combustion gases from the calciner are mixed before entering the preheater system. Figure 3-7 shows an SLC with a double-string cyclone preheater, with the combustion chamber/calciner placed in parallel to the kiln riser duct. Thus, combustion in the calciner takes place using heated atmospheric air drawn from the cooler through a separate tertiary air duct. The exhaust gas from the calciner and kiln is directed through the two independent preheater strings without being mixed.

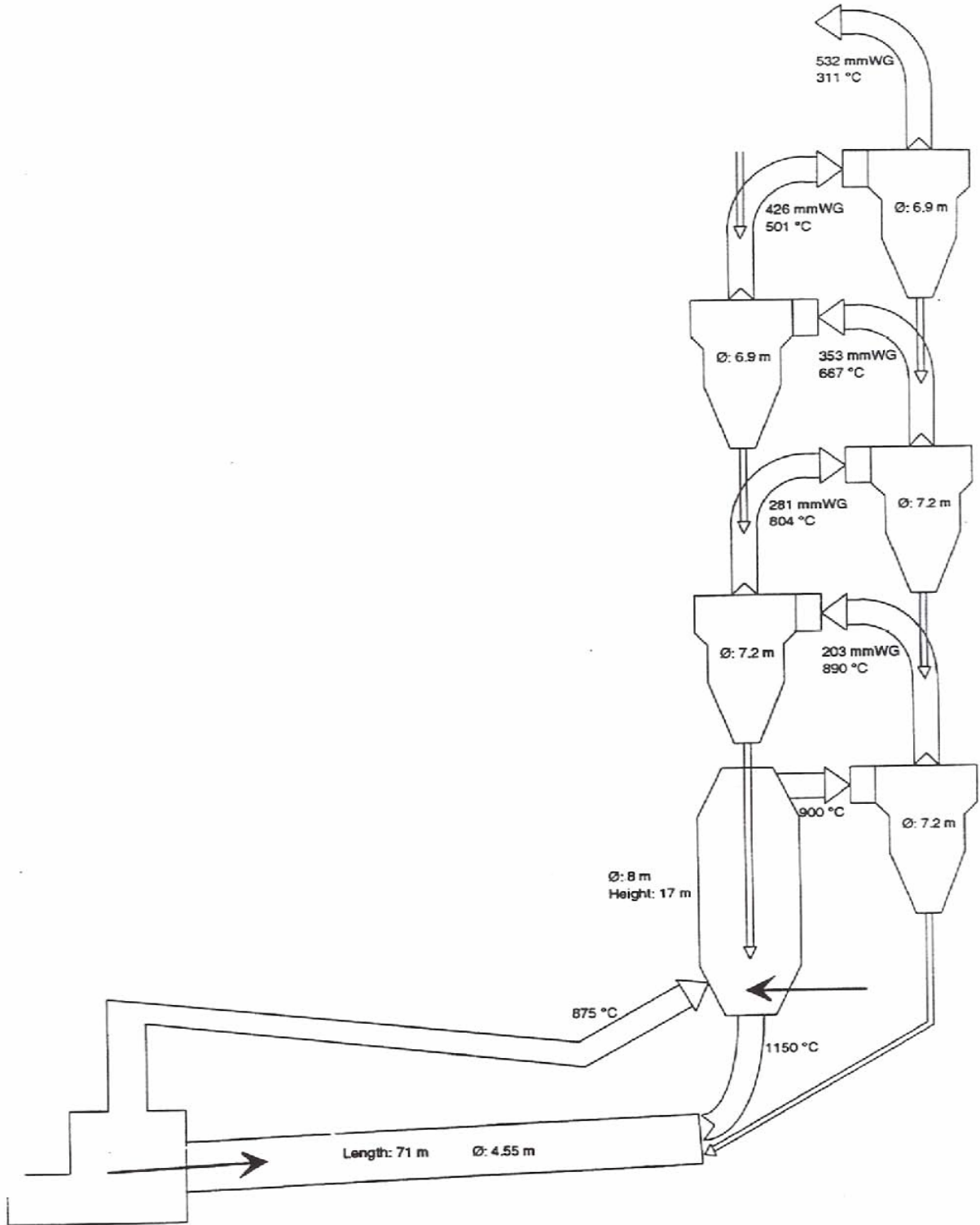

Figure 3-5. F.L. Schmidt ILC kiln system.⁹

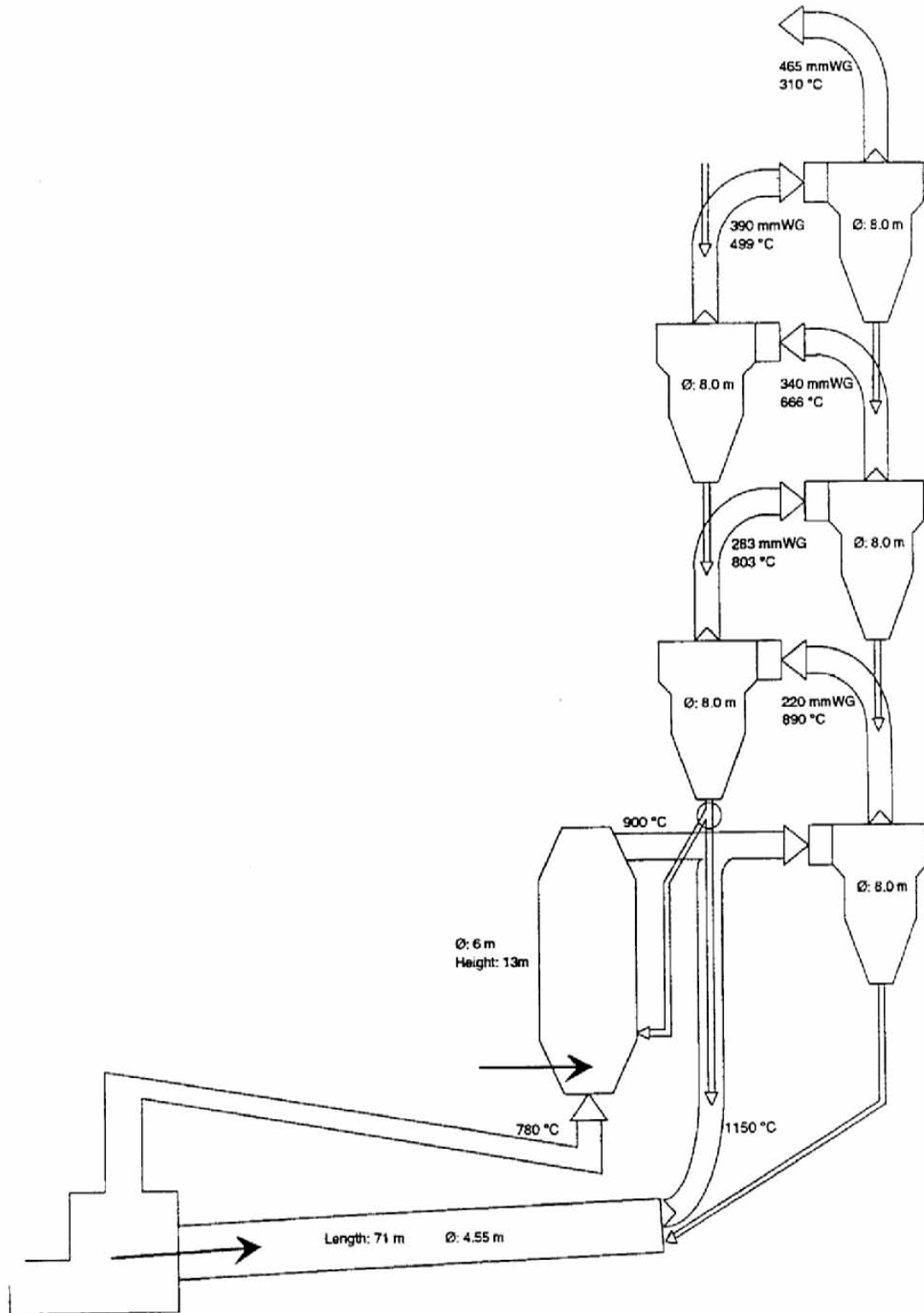

Figure 3-6. F.L. Schmidt SLC with single-string preheater.⁹

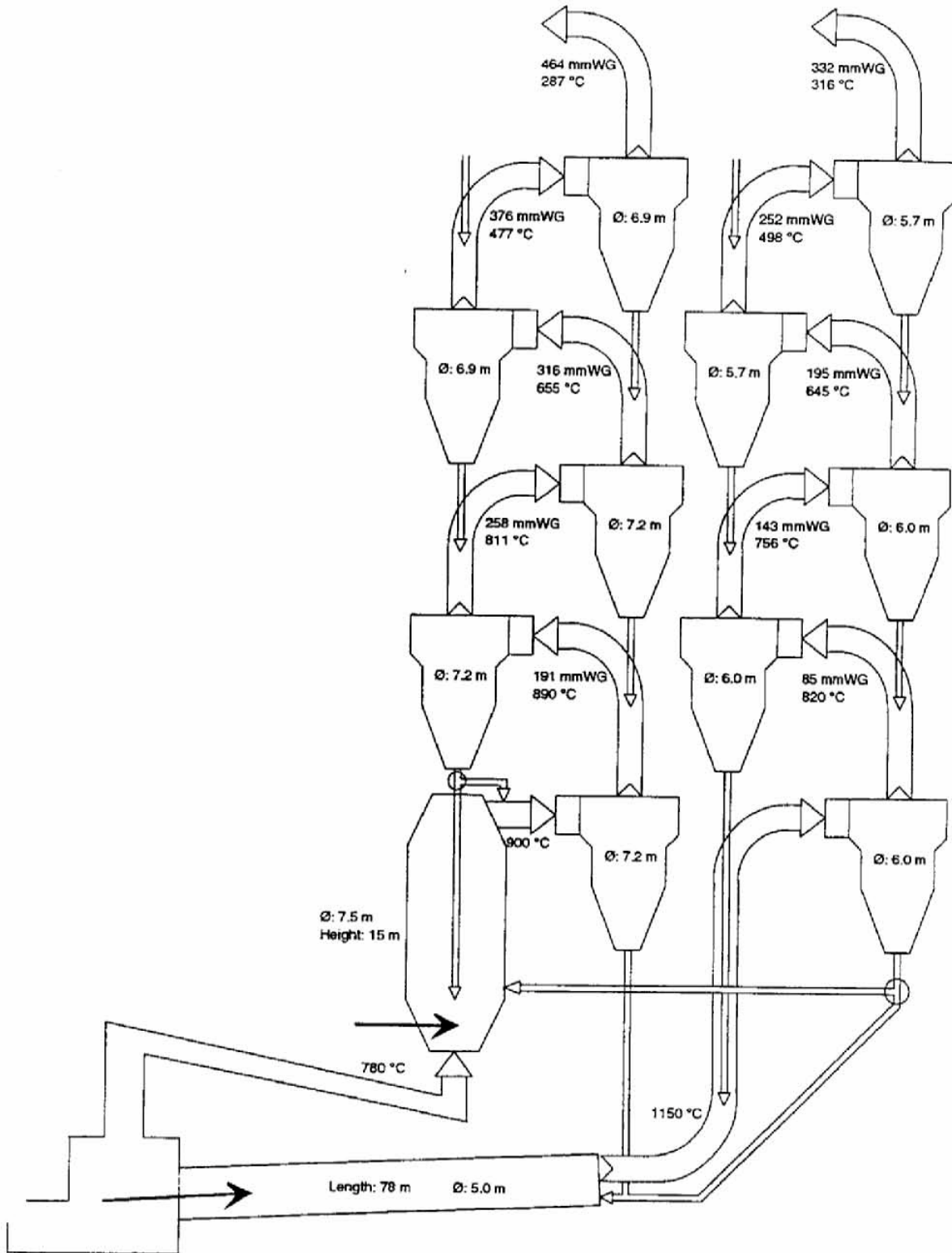

Figure 3-7. F.L. Schmidt SLC with dual-string preheater.⁹

3.2.3 Rotary Kiln

Upon leaving the calciner, the calcined material is transferred to the lowest cyclone of the tower, from where it enters the rotary kiln. The rotary kiln, where sintering (clinkering) occurs, is a cylindrical metal tube that is sloped (an incline of two to three degrees) and that turns about three to three and one-half revolutions per minute. The inside of the kiln is lined with refractory brick to protect the metal from the kiln's extreme temperature. The front (hot) end of the kiln (discharge end) contains a specially designed burner pipe, where fuel is fired to produce a high-temperature flame. The end of the kiln opposite the hot or discharge end is referred to as the feed end or rear of the kiln.

The process material enters the kiln at the feed end at a temperature of about 900 °C (1,650 °F). The gas temperature at this entry is about 1,000–1,100 °C (1,800–2,000 °F). The kiln's slight inclination and revolution causes the solid material to progress slowly through the kiln. As the feed progresses, the material and gas temperatures slowly increase. Two essential reactions occur in the rotary kiln of a PH/PC kiln system: 1) the remaining CO₂ is removed from the feed, and 2) the chemical reactions between the oxides of calcium, silicon, aluminum, and iron occur, producing a final product known as clinker. Cement clinker is a gray lava-like material that is produced in quantities about the size of a golf ball.

Many of the reactions in the rotary kiln are solid-phase or sintering reactions that occur at elevated material temperatures in close proximity to the kiln flame. This area is commonly known as the combustion zone of the kiln. The clinker minerals produced in the kiln are tetracalcium aluminoferrite ((CaO)₄ Al₂O₃Fe₂O₃), tricalcium aluminate ((CaO)₃ Al₂O₃), dicalciumsilicate ((CaO)₂SiO₂), and tricalcium silicate ((CaO)₃ SiO₂). The final reaction in the rotary kiln is the conversion of dicalcium silicate to tricalcium silicate, which only takes place above a minimum temperature in the range of 1,400–1,500 °C (2,550–2,750 °F). The reactions that occur in the rotary kiln can be represented as follows:

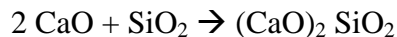
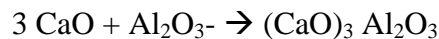
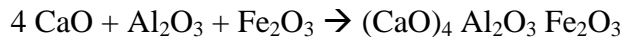

Clinker is produced by the chemical reaction of the dehydrated and decarbonated raw materials that occurs in the combustion zone of the rotary kiln at about 1,510 °C (2,750 °F). In the clinkering process, calcium oxide reacts at high material temperatures (1,400–1,500 °C [2,550–2,730 °F]) with silica, alumina, and ferrous oxide to form the silicates, aluminates, and ferrites of calcium that comprise the clinker. To achieve these material temperatures, gas phase temperatures will be substantially higher than 1,760 °C (3,200 °F). Oxidizing conditions must exist in the combustion zone to meet clinker quality demands; therefore, the kiln must be continuously monitored for oxygen and care must be taken to limit the amount of excess air in the system to maintain the maximum combustion zone temperature. About 20–25% of the material in the combustion zone is molten, and the cement clinker continues to change in character as it passes the zone of maximum temperature. The PH/PC kiln system permits the use

of smaller-dimension kilns because preheating, drying, and calcining take place in the PH/PC portion of the system and clinkering is carried out in the rotary kiln. About 40–50% of the total fuel is burned in the rotary kiln; the rest is burned in the calciner. The operation of a PH/PC kiln system is also more stable than other kiln types because 90% of the CO₂ in the feed is removed prior to the feed entering the rotary kiln.⁹ The total material retention time in the rotary kiln is about 30 minutes.

After passing the combustion zone of the rotary kiln, the clinker is cooled to about 1,250 °C (2,300 °F) before it is discharged from the kiln into the clinker cooler. In the cooler, ambient air is forced through the clinker bed to reduce the clinker temperature to about 100 °C (200 °F). Some of the heated air from the cooler is recovered and used for combustion air in the kiln (called secondary air) and for other processes, such as combustion air for the calciner. The residence time in the cooler is about 15–30 minutes. The purpose of the cooler is to recover heat from the hot clinker and to cool the clinker such that it can be conveyed for storage and/or to be ground into cement.⁷ The clinker that exits the cooler is stored or directly ground in a ball/roller mill system to produce cement. To produce Portland cement, the clinker is then ground or milled together with 4–5% gypsum.

3.2.4 Alkali Bypass – PH/PC Kiln Systems

Some PH/PC kilns are equipped with an air bypass system at the feed end of the kiln. This system is typically called an alkali bypass and consists of ducting, an ID fan, and an air-pollution control device. Although certain bypass systems can be designed to remove 10–100% of the kiln combustion gases, a typical bypass system removes between 15–30% of the kiln combustion gases. The gases exiting the kiln through the bypass are cooled with air or a combination of air and water.

As described previously, the quenching of the kiln exit gases can cause volatile compounds to condense on the fine particulate in the gas stream. Some raw materials and fuels used in the rotary kiln have volatile inorganic components that are compounds combined from the elements, including potassium, sodium, sulfur, and chlorine. These compounds have a relatively low melting point, and upon reaching the combustion zone of the kiln, will volatilize and be carried with the kiln gas to the preheater, where they condense either on the wall of the vessels or on the raw material (i.e., kiln feed) entering the kiln. The part of the volatile compounds condensed on the feed reenters the combustion zone and is again volatilized. This sets up an internal recirculation of volatile matter in the kiln gases entering the preheater. If the concentration of the volatile inorganic matter is great enough, and unless interrupted and removed from the kiln, it will eventually plug the vessels of the preheater. Even smaller build-ups in the preheater tower can restrict the amount of gas flow and greatly affect kiln operations. The bypass provides a valve to remove some of the volatile inorganic compounds from the kiln system to prevent such build-up in the preheater tower.

Another purpose of the bypass system is to remove excess alkali. Certain product quality standards have specific alkali limits. For example, to meet certain state highway department standards, the alkali content of some finished cements generally needs to be below a certain acceptable level. At high alkali levels, the alkalis in cement may react with certain aggregates to produce faulty concrete. To achieve low alkali in the finished cement requires low alkali levels in

the clinker. In a PH/PC kiln, alkalis are re-condensed on the cooler feed coming from the calciner and reenter the combustion zone of the kiln, where they are volatilized. A bypass system can be used to break this cycle and reduce the alkali content in the clinker. Because a certain amount of air and dust (raw material that has been partially calcined) is being wasted to remove the alkali inorganic material, a bypass on a cement kiln typically involves a fuel penalty between 16,000–20,000 Btu/t of clinker for every 1% of kiln gas that is bypassed. The amount of bypass required is determined primarily by the alkali and volatile inorganic content of the kiln feed. The amount of dust wasted typically ranges from 80–100 tons per day (t/day), depending on the size of the kiln system and the percent of gas bypassed. Not all PH/PC kiln systems require a bypass system, and the amount of kiln gas bypass varies during operations, as dictated by cement quality, production specification, and process.

3.3 REFERENCES

1. U.S. Environmental Protection Agency. *Technology Transfer Network, Clean Air Technology Center. RACT/BACT/LAER Clearinghouse*. Web site: www.epa.gov/ttn/catc. Accessed March 6, 2007.
2. Florida Department of Environmental Protection. *Technical Evaluation, Preliminary Determination, Draft BACT Determination, Sumter Cement Company*. December 21, 2005. Available at www.dep.state.fl.us/Air/permitting/construction/american/TEPD358.pdf.
3. Environment Canada. *Foundation Report of the Cement Manufacturing Sector*. Draft #1. Prepared by Minerals and Metals Branch, Pollution Prevention Directorate. June 18, 2004.
4. Greer, W.L., and C.D. Lesslie. *Variability of NO_x Emissions from Precalciner Cement Kiln Systems*. Trinity Consultants. Control #80. Undated.
5. Natural Resources of Central Florida. *Report in Support of an application for a PSD Construction Permit Review*. American Cement, Sumterville, FL. October 4, 2005. Available at <http://www.dep.state.fl.us/air/permitting/construction/american>.
6. U.S. Environmental Protection Agency. *NO_x Control Technologies for the Cement Industry*. Prepared by EC/R Incorporated. September 19, 2000. Available at www.epa.gov/ttn/naaqs/ozone/ozonetech/cement_nox_update_09152000.pdf.
7. U.S. Environmental Protection Agency. *Alternative Control Techniques Document – NO_x Emissions from Cement Manufacturing*. EPA-453/R-94-004. March 1994. Available at www.epa.gov/ttn/cata/dir1/cement.pdf.
8. U.S. Environmental Protection Agency. *11.6 Portland Cement Manufacturing*. AP 42, Chapter 11.6. Available at <http://www.epa.gov/ttn/chief/ap42/ch11/final/c11s06.pdf>.
9. Portland Cement Association. *Report on NO_x Formation and Variability in Portland Cement Kiln Systems Potential Control Techniques and Their Feasibility and Cost Effectiveness*. PCA R&D Serial No. 2227. Prepared by Penta Engineering Corporation. 1999.

4.0 NO_x EMISSIONS FROM PH/PC KILNS

The high temperatures and oxidizing atmosphere required for cement manufacturing are also favorable for NO_x formation. In cement kilns, NO_x emissions are formed during fuel combustion by two primary mechanisms:

1. The oxidation of molecular nitrogen present in combustion air (thermal NO_x)
2. The oxidation of nitrogen compounds in fuel (fuel NO_x).¹

Sometimes, the raw material feed may also contain nitrogen compounds, which may lead to feed NO_x similar to fuel NO_x. Because of the high temperatures involved in burning or clinker formation, thermal NO_x is the dominant mechanism for NO_x formation in kiln systems.

4.1 THERMAL NO_x

Thermal NO_x results from the homogeneous reaction of oxygen and nitrogen in the gas phase at high temperatures. In the overall reaction mechanism developed by Zeldovich, the two important steps in the formation of thermal NO_x are the following:

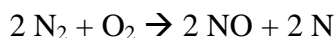

The excess air used during fuel combustion can substantially affect NO formation by determining the amount of oxygen available for NO reaction. The cement kiln combustion zones usually have about 5–10% excess air, although higher excess air levels are not uncommon. Higher excess air levels result in higher NO_x. Also, as shown in Figure 4-1, small increases in temperature result in very large increases of NO concentrations at temperatures above 1,430 °C (2,600 °F).

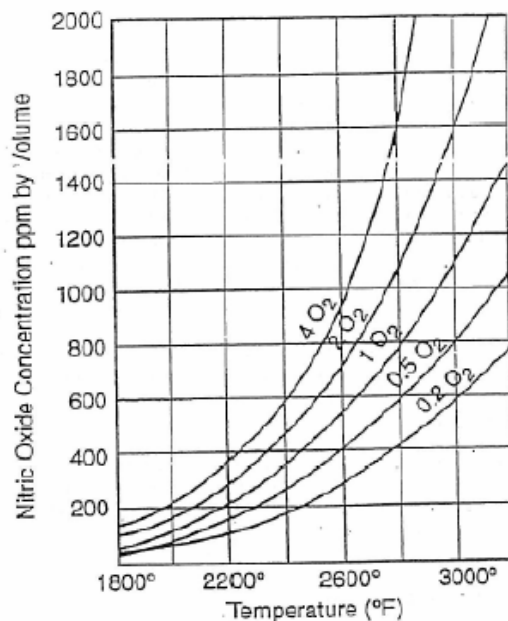

Figure 4-1. NO vs. temperature at various O₂ levels.²

Fuel combustion in the kiln combustion zone is the primary source of thermal NO_x in cement kilns due to temperatures well above 1,400 °C (2,550 °F). In comparison, the fuel combustion temperature in a calciner or in a kiln riser duct is well below 1,200 °C (2,200 °F), thereby suppressing thermal NO_x formation. Mainly fuel and feed NO_x is formed in the preheater and precalciner. Along with the combustion temperature, the gas-phase residence time and available oxygen concentration in the kiln's high-temperature combustion zone are important parameters. Longer residence times at high temperatures and greater amounts of oxygen in the combustion zone will increase NO_x. Once NO_x is formed, the decomposition of NO_x at lower temperatures, although thermodynamically favorable, is kinetically limited.³

Nitrogen in combustion air is oxidized to NO_x (thermal NO_x) at a flame temperature of 1,870 °C (3,400 °F) in a rotary kiln, which heats the process material to 1,480 °C (2,700 °F). The calciner of a PH/PC kiln operates near 1,200 °C (2,200 °F), at which point the formation of thermal NO_x essentially ceases. Thus, thermal NO_x dominates NO_x formation in the combustion zone of a rotary kiln and is a lesser factor in NO_x formation in the calciner or elsewhere in the system.⁴

Each kiln has a different kiln temperature profile due to the uniqueness of the chemical composition of the raw materials and the specific desired qualities of the clinker. Different raw materials require different flame temperatures. For example, if the raw materials have a higher alkali content than preferred in the finished product, higher flame temperatures are used to remove (volatilize) the excess alkali. These higher temperatures increase the fuel consumption per ton of product and also increase NO_x formation. The residence time also affects NO_x concentration.

4.2 FUEL NO_x⁴

Fuel NO_x is formed by the oxidation of nitrogen present in fuel. The oxidation reactions of nitrogen from fuel are complex and occur through many intermediate products and radicals. As the fuel burns, the nitrogen that was chemically bonded as part of the fuel molecule is freed and can combine with oxygen to form NO_x.⁵ About 80% of the energy requirements for the PH/PC kiln systems are met by coal, whereas natural gas provides only 3%, oil provides less than 1%; and other fuels such as waste solvents provide 14%. Oil and natural gas have relatively low fuel-bound nitrogen content, whereas coal may have 1–3% nitrogen by weight. In addition, waste-derived fuels (e.g., scrap tires, used motor oils, paint thinners) are being used increasingly as fuel for PH/PC kilns and may have significant nitrogen content.

The maximum possible fuel NO_x conversion can be estimated for a PH/PC kiln system. As shown in Table 3-3, the heat input requirement for this type of kiln is 3.3 mmBtu/t of clinker. Assuming a coal heating value of 12,000 Btu/lb, 275 lb of coal would be required per ton of clinker. With a nitrogen content of 1% by weight, approximately 5.9 lb of NO_x would be produced per ton of clinker, assuming 100% nitrogen conversion.

Because kiln measurements indicate the total NO_x formed, it is difficult to distinguish the levels of thermal NO_x and fuel NO_x. In general, thermal NO_x is thought to be the dominant mechanism in cement kilns. Gas burners produce more intense and hot flames compared to coal burners; thus, gas-fired kilns may be expected to produce greater thermal NO_x than coal-fired kilns. A study has indicated that gas-fired, dry-process kilns typically produce almost three times more NO_x than coal-fired, dry-process kilns.

Fuel NO_x predominates NO_x generation in the calciner and at lower-temperature combustion sites. Fuel NO_x also occurs in the combustion zone of a rotary kiln.⁷ Approximately 60% of fuel nitrogen is converted to NO_x and is dependent upon available oxygen in the flame and temperature profile of the flame.⁸

When fired in the main kiln burner, natural gas has been shown to generate approximately twice the amount of NO_x per ton of clinker as coal or oil. This is not readily apparent because the adiabatic flame temperatures of coal and oil are higher than for natural gas. In addition, coal and oil have more fuel nitrogen than natural gas and are generally fired with a higher volume of combustion air, which increases the oxygen available and the potential for NO_x formation. There are other factors associated with coal and oil burning that more than offset the factors mentioned above, including flame shape, the luminescence of the flame and higher levels of CO, and various radicals that counter NO_x formation.

Calciner kilns burn 50–60% of the total fuel at a lower temperature (1,200 °C [3,630 °F]) in the kiln. This leads to negligible thermal NO formation in the calciner; thus, thermal NO_x in PH/PC kiln systems is much lower than other kiln types.⁹

About 15–30% of fuel NO_x is converted in the calciner in the absence of tertiary air, and 30–75% is converted when tertiary air is supplied. In a low NO_x calciner, NO_x levels in the gases exiting the preheater are 35–50% lower than kilns without calciners.⁶

4.3 FEED NO_x¹⁰

Feed NO_x is generated when nitrogen in the raw materials that are fed to the kiln are oxidized. The raw materials used in cement production may contain a significant amount of nitrogen. Limestone is the major raw material, with the remainder of the raw mix being clays, shales, sandstones, sands, and iron ore. The nitrogen content for various kiln feeds ranges from 20 to 1,000 parts per million (ppm). 100 ppm of nitrogen in the kiln feed is equivalent to about 1 lb of NO_x per ton of clinker if all the nitrogen in the feed is converted.

The conversion of feed nitrogen to NO_x occurs mainly in the 300–800 °C (570–1,470 °F) range and depends on the feed heating rate. The rapid heating of raw materials in PH/PC kiln system is thought to result in less NO_x feed generation than the slower heating of kiln feed found in other types of kiln. Rapid heating rates (~ 100 °C flash heating) of the kiln feed mixtures were found to give much lower conversion efficiencies, whereas a slow heating rate of kiln feed mixtures (~60 °C/min) gave a fairly high conversion (about 50% of bound nitrogen to NO). The explanation for this is the assumption that organic nitrogen must vaporize from the sample prior to oxidation if high conversion efficiencies to NO_x are to be achieved. If heating rates are rapid, “cracking” of these volatile compounds may occur in situ, which may result in conversion of the bound nitrogen directly to N₂ before it comes into contact with gaseous oxygen, thus reducing the fraction converted to NO_x; therefore, feed NO_x is not likely to be a significant contributor to NO_x emissions from a PH/PC kiln system.

4.4 PROMPT NO_x

Prompt NO_x is formed when free radicals from the fuel react with available N₂ in the combustion air. Free radicals are generated by the use of excess fuel-forming HC radicals, which rapidly react with N₂ to form hydrogen cyanide (HCN) and nitrogen. Through a cascade of reactions, NH₃ can also form. As combustion continues, the HCN and NH₃ result in the generation of NO_x. These reactions are summarized as follows:

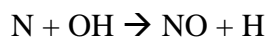

The rate of formation of prompt NO_x is very rapid, and reactions are not strongly temperature dependent and occur in a fuel-rich environment. The contribution of prompt NO_x to overall NO_x formation in a cement kiln is small because prompt NO_x tends to dominate when the total NO_x concentration in the system is low, but in cement kilns, the NO_x concentrations are relatively high.

4.5 REFERENCES

1. Environment Canada. *Foundation Report of the Cement Manufacturing Sector*. Draft #1. Prepared by Minerals and Metals Brand, Pollution Prevention Directorate. June 18, 2004.

DRAFT – DO NOT QUOTE OR CITE

2. Zeldovich, J. 1946. The Oxidation of Nitrogen in Combustion and Explosions. *Acta Physiochem.* 1946.
3. U.S. Environmental Protection Agency. *NO_x Control Technologies for the Cement Industry*. Prepared by EC/R Incorporated. September 19, 2000. Available at www.epa.gov/ttn/naaqs/ozone/ozonetech/cement_nox_update_09152000.pdf.
4. Greer, W.L., and C.D. Lesslie. *Variability of NO_x Emissions from Precalciner Cement Kiln Systems*. Trinity Consultants. Control #80. Undated.
5. Webster, T., and S. Drennen. *Low NO_x Combustion of Biomass Fuels*. Available at http://www.coen.com/i_html/white_lownoxbiom.html. Accessed August 2, 2006.
6. U.S. Environmental Protection Agency. *Technology Transfer Network, Clean Air Technology Center. RACT/BACT/LAER Clearinghouse*. Web site: www.epa.gov/ttn/catc. Accessed March 6, 2007.
7. Florida Department of Environmental Resources. *BACT Determination – Suwannee American Cement, Branford Florida*. Air NSR/PSD Construction Permits. Available at <http://www.dep.state.fl.us/Air/permitting/construction/suwannee.htm>. Accessed March 6, 2007.
8. Natural Resources of Central Florida. *Report in Support of an application for a PSD Construction Permit Review*. American Cement, Sumterville, FL. October 4, 2005. Available at <http://www.dep.state.fl.us.air/permitting/construction/sumter>.
9. Tokheim, L.-A. *The Impact of Staged Combustion on the Operation of a Precalciner Cement Kiln*. Telemark College, Porsgrumm, Norway. Available at [www.cement.org/dnld/Staged percent20 Combustion percent20Dissertation.pdf](http://www.cement.org/dnld/Staged%20Combustion%20Dissertation.pdf).
10. Greer, W.L., and C.D. Lesslie. *Variability of NO_x Emissions from Precalciner Cement Kiln Systems*. Trinity Consultants. Control #80. Undated.

5.0 FACTORS AFFECTING NO_x EMISSIONS

As discussed in Section 3, high temperatures are necessary for the required clinkering reactions to take place in the cement kiln. If a kiln's temperature drops too low, the clinker formation reactions will stop, and because these reactions are exothermic, the temperature will drop even further. The temperature must be raised by increasing the energy (fuel) input to the kiln. Once the clinkering formation reactions start again, the temperature will increase very rapidly, again requiring an adjustment of fuel input. These process variations, which result in temperature variations, are normal in cement kiln operations and can produce significant variations in NO_x emissions.

Changes in the fuel used for kilns can also change a kiln's temperature and the shape of the kiln flame, which can precipitate temperature changes in the kiln combustion zone. Flame temperatures are greater for gas burners than for coal burners. In addition to temperature variations that can initiate thermal NO_x formation, fuels with higher nitrogen content will have more nitrogen available for fuel NO_x formation.

As with fuel, changes in the feed rate, chemical composition, or moisture content of raw materials can also change a kiln's operating parameters. Even raw materials from the same quarry can vary in chemical composition from day to day. Materials with higher nitrogen content can lead to more feed NO_x formation. Raw materials that contain unacceptably high alkali content must be heated longer and at higher temperatures to volatilize and remove the alkali compounds. If alkali compounds are volatilized from the raw material, they appear in the kiln exhaust gases. As discussed in Section 3, a bypass system can be used to control these alkali emissions. In a bypass system, a portion of the kiln exhaust gases is rapidly cooled or quenched in order for the alkali materials to condense and be collected directly by a particulate control device. This lowers the overall system heat efficiency, requiring more energy to be added to the system, again contributing to additional NO_x formation.

The energy efficiency of a kiln system can also affect NO_x formation. As clinker exits the kiln, it is cooled with ambient air. The heat from the clinker is transferred to the air, and this heated air is recycled to preheat a significant portion of the secondary combustion air and to reach the high flame zone temperatures necessary for Portland cement production. In addition, some heat-recovery methods require less energy input into the kiln. This reduced heat (and fuel) input into the kiln system reduces the formation of NO_x.

Excess oxygen is required to produce quality clinker, but higher oxygen levels result in higher NO_x emissions. The oxygen concentration in the combustion zone depends on the percentage of excess air used and the ratios of the primary and secondary combustion. Additional combustion for PH/PC kilns takes place in the calciner. As noted in Section 3, secondary combustion air may be used for combustion in the calciner. The secondary combustion air usually comes from the clinker cooler; however, some calciners will use kiln gases as the source of combustion air rather than secondary air from the cooler. The source of the secondary and primary air determines the air's oxygen content. Less primary air means less oxygen and may produce an initial high-temperature, fuel-rich combustion zone, followed by a low-temperature fuel-lean combustion zone. Such a combination is likely to reduce the formation of NO_x.

The proportions of primary and secondary combustion air are affected by the type of firing system used in the kiln. Direct-fired systems use combustion air to transport fuel into the kiln. Therefore, a large proportion of the combustion air is introduced with the fuel as primary air. This produces two conflicting effects for NO_x emissions: higher oxygen concentrations and lower gas temperatures. In contrast, indirect-fired systems use only a small portion of combustion air to convey fuel; thus, these systems use less cold primary air. Therefore, indirect-fired systems use more secondary air with additional heat value as the combustion air. In general, direct-fired systems may be expected to produce greater NO_x emissions compared to indirect-fired systems. The majority of kilns in the United States are direct-fired systems.

6.0 PROCESS CONTROLS THAT REDUCE NO_x EMISSIONS^{1,2}

The primary goal of process controls is to stabilize process parameters and kiln conditions. The process controls used to stabilize kiln operations also improve energy efficiency by reducing heat consumption, improve clinker quality, and increase the life of the cement plant. Another beneficial effect of process controls is the reduction of NO_x emissions because of improved fuel efficiency.

When determining uncontrolled NO_x emissions, the following standard operating practice (SOP) components should be considered. These SOPs are incorporated by all new PH/PC kiln systems.

- Combustion zone control of temperature and excess air through continuous monitoring of temperature and excess air
- Feed mix composition
- Kiln fuel type
- Increased thermal efficiency
- Staged combustion in kiln
- Efficient cooler control
- Expert control systems
- Low NO_x burners in the kiln.

These components are discussed in detail in previous EPA documents.^{1,2} A summary of these measures is contained in the following subsections.

6.1 COMBUSTION ZONE CONTROL OF TEMPERATURE AND EXCESS AIR^{1,2}

Continuous monitoring of CO and O₂ emissions in the exhaust gases of cement kilns indicates the amount of excess air. At any given excess air level, NO_x emissions increase as the temperature of the combustion zone increases. Keeping the combustion zone temperature at a minimum acceptable value minimizes the process energy requirements and NO_x emissions.

With continuous CO, O₂, and NO_x monitors and feedback control, excess air can be accurately controlled to maintain a level that provides optimum combustion and lower NO_x emissions. Reducing excess air levels also results in increased productivity per unit of energy; thus, resulting in the indirect reduction of NO_x emissions per amount of clinker produced.

6.2 FEED MIX COMPOSITION

Heat requirements for producing clinker are dependent on the composition of the raw material. Experiments have demonstrated that by improving the burnability of the kiln feed, the heat requirements for producing clinker can be reduced by 15%, thereby requiring less fuel (i.e., less heat input per ton of clinker) and producing less NO_x per unit of product. This approach of changing feed composition may be highly site specific and may not be applicable to all locations.

The level of heat input required to complete the clinkering reactions depends on the chemical and moisture composition of the raw feed materials. Raw materials can vary widely between cement plants, as well as within the same plant. One example of this practice is to use

raw materials with as low an alkali content as possible because high alkali materials require more heat and a longer residence time to volatilize.

If the raw materials are consistently proportioned and blended before entering the kiln, the temperatures and excess air requirements should remain constant. Keeping temperatures as low and as constant as possible reduces the overall energy requirements, increases fuel efficiency, and reduces NO_x formation.

6.3 KILN FUEL

The type of kiln fuel used directly affects the formation of NO_x. Using coal instead of natural gas results in lower uncontrolled NO_x emissions because the flame temperature for coal is significantly lower than natural gas. In one study of dry process kilns, the average NO_x emissions decreased from 20.4 to 6.2 lb/t of clinker when the fuel was changed from natural gas to coal. Approximately 80% of primary fuel burned in cement kilns is coal.

For PH/PC kiln systems, emissions of NO_x range from 1.7–3.0 kg/t of clinker (3.7–6.6 lb/t) for kiln systems fueled by natural gas and 1.35–1.95 kg/t of clinker (3.0–4.3 lb/t) for kiln systems fueled by coal.³

6.4 INCREASING THERMAL EFFICIENCY

As shown in Table 3-3, the PH/PC kiln system is the most energy efficient of the cement kilns. The energy efficiency benefit varies from 15–30% depending on the type of conventional kiln system used for comparison. The thermal efficiency of the PH/PC kiln system may be increased by improving gas/solids heat transfer (e.g., by using an efficient chain system, increasing the heat recovery from the clinker cooler by increasing the proportion of secondary air, and minimizing infiltration of ambient air leakage into the kiln).

6.5 STAGED COMBUSTION IN KILN

The staging of fuel combustion occurs in two distinct zones. In the first zone, initial combustion is conducted in a primary fuel-rich zone. This zone provides the high temperatures needed for completion of the clinkering reactions. Due to the fuel-rich conditions and the lack of available oxygen, the formation of thermal and fuel NO_x is minimized. In the second zone, fuel combustion is completed, with additional (secondary) combustion air added to complete the combustion process. The gas temperature in the second zone is much lower than the first zone because the gas is mixed with cooler secondary air, thereby minimizing NO_x formation despite the excess available oxygen in this zone. Indirect-fired kilns are required for effective staging of combustion air.

6.6 EFFICIENT COOLER CONTROL⁴

Improved heat recovery from the clinker cooler will result in better fuel efficiency for the PH/PC system. Heat recovered from the clinker cooler does not need to be generated from fuel burning. Other ways to improve the reuse of heat from the clinker cooler include optimizing the cooler's layout and the design of the ID fan.

6.7 EXPERT CONTROL SYSTEMS ⁴

During clinker production, variables such as excess air should be maintained close to the process “setpoints” required to minimize NO_x formation. Excess air can be controlled with continuous monitoring systems that measure oxygen, CO₂, and NO_x levels. When excess air is optimized, burning conditions, temperature, and fuel use are also optimized, which in turn minimizes the formation of NO_x.

The use of computerized, automated systems to read and interpret process conditions and to make any necessary process adjustments can eliminate most lag time or operator errors. Process parameters can also be kept close to ideal conditions, minimizing kiln operation variations and upsets.

6.8 LOW NO_x BURNERS (LNB) IN KILN

Low NO_x burners (LNB) have been used by the cement industry for nearly 30 years and are designed to reduce flame turbulence, delay fuel/air mixing, and establish fuel-rich zones for initial combustion. The longer, less-intense flames resulting from SC lower flame temperature and reduce thermal NO_x formation by approximately 30%. For more details on LNB, see the earlier NO_x ACT documents.

Two distinct combustion zones are created using LNBs. Flame turbulence and air and fuel mixing are suppressed during the first stage of combustion. A fuel-rich, oxygen-lean, high-temperature combustion zone is created first by reducing the amount of primary air in the primary combustion zone and delaying the combustion of all of the fuel. A portion of the flue gas can be recycled into the primary combustion zone to reduce the oxygen content of the primary air and produce a fuel-rich atmosphere. The recycled flue gas can be premixed with the primary combustion air or injected directly into the flame zone. Although temperatures are high, as required to complete clinkering reactions, thermal NO_x formation is suppressed in the primary combustion zone because less oxygen is available.

A secondary, oxygen-rich combustion zone follows, where fuel combustion is completed. Cooler secondary combustion air is mixed into the secondary combustion zone, lowering the temperature. Although excess oxygen is available, NO_x formation is suppressed in the secondary combustion zone because of lower temperature.

A cement kiln in which less than 10% of the total combustion air is primary air is considered an indirect-fired kiln. LNB can only be used with indirect-fired kiln systems. Indirect firing allows a greater proportion of recycled clinker cooler air to be used as secondary combustion air.

As discussed in the two earlier EPA reports,^{1,2} uncontrolled NO_x emissions from PH/PC cement kilns are lower than other kiln types. Table 6-1 summarizes these results. These numbers are based on data compiled for the 1994 ACT document. Calciner kilns have lower NO_x emission rates than other cement kiln types because they burn more fuel at the calcining temperature. They are also the most energy efficient kiln type. Based on data from the earlier ACT report, uncontrolled emissions for the other kiln types are 55–155% higher than the PH/PC

kiln system,² Based on AP-42 emission factors for the various kiln types, these differences range from 14 to 76%.⁵

Table 6-1. Uncontrolled NO_x Emissions (lb/t) – Cement Kilns^{2,5}

Kiln Type	Range	Average/ Percent Higher than Calciner	AP-42/ Percent Higher than Calciner
Wet	3.6–19.5	9.7 /155	7.4 /76
Long Dry	6.1–10.5	8.6 /126	6.0 /43
Preheater	2.5–11.7	5.9 /55	4.8 /14
PH/PC	0.9–7.0	3.8 /----	4.2 /----

6.9 REFERENCES

1. U.S. Environmental Protection Agency. *NO_x Control Technologies for the Cement Industry*. Prepared by EC/R Incorporated. September 19, 2000. Available at www.epa.gov/ttn/naaqs/ozone/ozonetech/cement_nox_update_09152000.pdf.
2. U.S. Environmental Protection Agency. *Alternative Control Techniques Document – NO_x Emissions from Cement Manufacturing*. EPA-453/R-94-004. March 1994. Available at www.epa.gov/ttn/cata/dir1/cement.pdf.
3. Environment Canada. *Foundation Report of the Cement Manufacturing Sector*. Draft #1. Prepared by Minerals and Metals Brand, Pollution Prevention Directorate. June 18, 2004.
4. Portland Cement Association. *Report on NO_x Formation and Variability in Portland Cement Kiln Systems Potential Control Techniques and Their Feasibility and Cost Effectiveness*. PCA R&D Serial No. 2227. Prepared by Penta Engineering Corp. 1999.
5. U.S. Environmental Protection Agency. *11.6 Portland Cement Manufacturing*. AP 42, Chapter 11.6. Available at <http://www.epa.gov/ttn/chief/ap42/ch11/final/c11s06.pdf>.

7.0 STAGED COMBUSTION

There are many ways a PH/PC kiln system could be considered to be using staged combustion (SC). First, the processes of the PH/PC kiln system itself, which include the drying, calcining, and sintering of the raw materials, can be considered SC. Also, the kiln with a multi-channel main kiln burner with indirect firing incorporates SC. All calciners have some degree of SC. The use of low NO_x calciners, which inject fuel near the kiln inlet, is a form of SC. This section will discuss SC in the calciner (SCC).

7.1 SCC MECHANISM

The various zones of the PH/PC kiln system are shown in Figure 7-1. In the PH/PC kiln system, NO_x formation occurs in the rotary kiln under oxidizing conditions. Fuel is then added to the kiln exhaust gas, in the kiln inlet, or in the kiln riser duct so that a reducing zone (a zone where less air is available than would be required for complete combustion) is created. This promotes the reduction of NO_x to molecular oxygen. Finally, air is added in the upper part of the calciner (the burnout zone) to complete burnout or complete combustion of the fuel.¹

SCC works by staging the introduction of fuel, combustion air, and raw meal in a manner to minimize NO_x formation and reduce NO_x to nitrogen. NO_x formed in the kiln's combustion zone is chemically reduced by maintaining a reducing atmosphere at the kiln feed end by firing fuel in this region. The reducing atmosphere is maintained in the calciner region by controlling combustion air such that the calcining fuel is first burned under reducing conditions to reduce NO_x, and then burned under oxidizing conditions to complete the combustion reaction. Controlling the introduction of raw meal allows for control of the calciner temperature. Through these mechanisms, both fuel NO_x and thermal NO_x are controlled. The combustion chamber allows for improved control over the introduction of tertiary air in the calciner region, which helps to promote the proper reducing environment for NO_x control.²

All new PH/PC kiln systems are designed with multistage combustion (MSC) calciners. MSC is actually the version of SC as applied by Polysius. There are several SCC variations based on fuel staging or air staging (or both) (see Sections 7.2.1 through 7.2.3 for descriptions). According to a Florida Department of Environmental Protection (DEP) expert, the best version of SCC would be an SCC with High Temperature Reducing Atmosphere (HTRA). HTRA is achieved when some or all calciner fuel is burned under aggressive reducing (substoichiometric air) and at temperatures significantly higher than calcination temperature. Under such conditions, the gas phase reactions that destroy NO_x proceed very rapidly and are catalyzed by raw meal. Some additional reduction takes place at lower (calcination) temperature as you get char combustion. The lower NO_x emission level achieved by SCC with HTRA is 2.0 lb/t of clinker.

A key component of SCC is the kiln inlet burner that creates a high-temperature reducing atmosphere. Some projects are considered to be SCC even when they achieve a mild reducing atmosphere. Some SCC have a high NO_x limit and are operated under an oxidizing atmosphere which is easier for operations.³

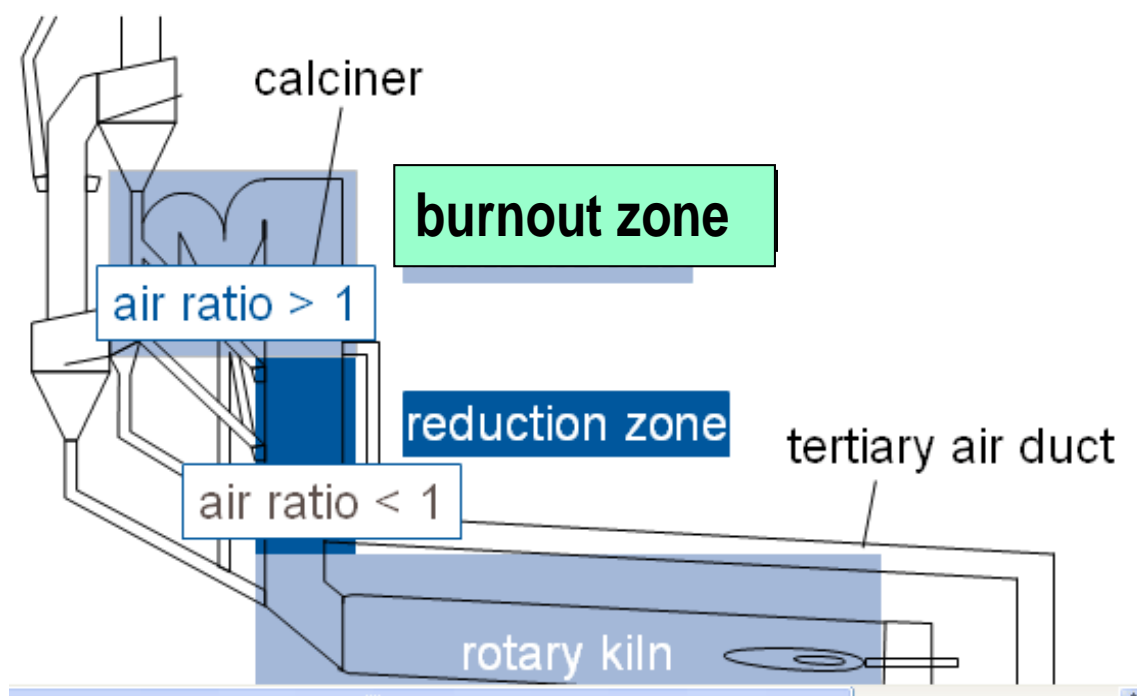

Figure 7-1. Principle of NO_x reduction by SCC.⁴

SCC involves four combustion stages. The first stage is the rotary kiln, where clinker burning can be optimized. The second stage is the kiln feed inlet, which provides reducing conditions for NO_x generated during the sintering process. In the third stage, fuel is introduced into the calciner to calcine the raw meal. This calcining fuel is introduced with tertiary air to create a reducing atmosphere. The last stage is when the remaining tertiary air is introduced as “top-up air” to complete the residual combustion process.⁵ SCC systems are complex and require integrated monitoring and control systems to closely monitor temperature, fuel, feed, and combustion air addition rates. If raw materials are not completely oxidized in the calciner and preheater, CO emissions may increase.

The factors affecting NO_x levels for SCC are summarized in Table 7-1.

Table 7-1. Parameters Affecting NO_x and Staged Combustion Responses⁶

Kinetic Parameters Influencing NO _x	Process Parameter Influencing NO _x	Measures for NO _x Reduction
Oxygen concentration	Air-to-fuel ratio	Air staging
NO concentration	NO at kiln inlet	Decrease O ₂ in rotary kiln
NH ₃ , HCN, HC, CO concentrations	Residence time	Calciner design
Same as above	Mixing of gas streams	Adjustment of burners, distribution of meal, and tertiary air
Same as above	Fuel properties	Increase fineness, change fuel
Temperature	Temperature	Meal staging

7.2 THREE TYPES OF SCC ⁷

7.2.1 Staged-Air

One type of SCC system is a staged-air combustion system, such as the system located at Suwannee American Cement (SAC) in Branford, FL (Figure 7-2). With staged-air combustion, the calciner burner is vertically orientated in a separate combustion chamber of the type typically used for difficult-to-burn units, such as petroleum coke. In this case, the calciner is used to burn fuel (coal) in a reducing atmosphere to destroy NO_x in the kiln exhaust. The unit at SAC is supplied by Polysius; a similar calciner is the Minox Low NO_x calciner.

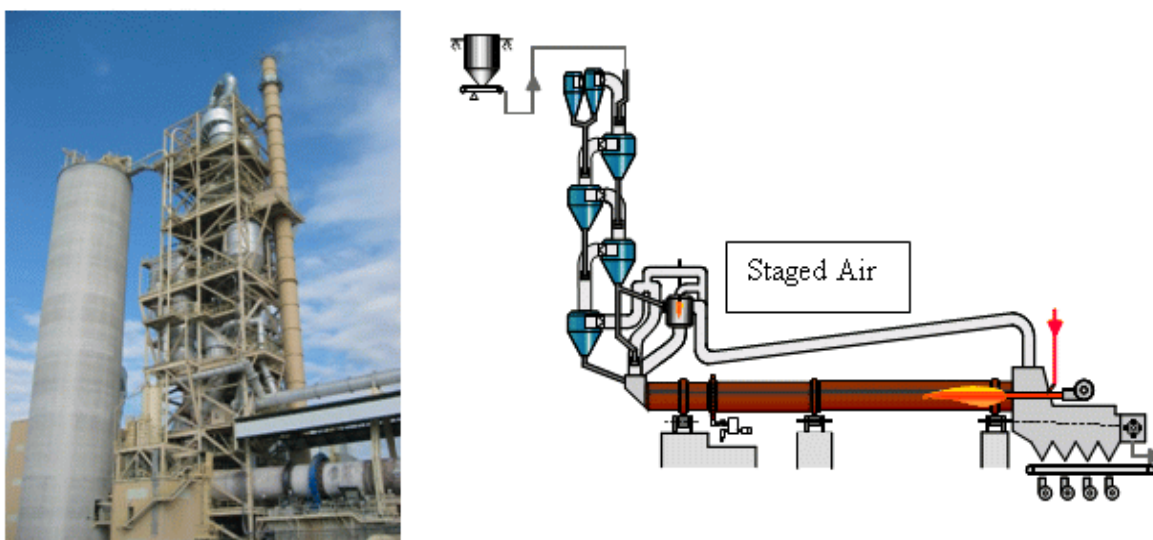

Figure 7-2. Suwannee American Cement, Branford, Florida, staged-air SCC.⁷

The SAC plant in Branford has a BACT NO_x emissions limit of 2.9 lb/t of clinker on a 24-hour rolling average basis. The Branford kiln does not fire fuel at the kiln inlet; however, a burner is provided for that purpose. Therefore, the version of SCC at the SAC plant achieves a reducing atmosphere in the calciner, but not a high-temperature reducing zone near the kiln inlet. Under this scenario, typical NO_x emissions vary between 2.2 and 2.6 lb/t of clinker. Assuming a baseline of 3.5 lb/t of clinker, this version of SCC achieves NO_x reductions of approximately 25–40%.

Figure 7-3 shows the SCC configuration used during tests conducted in June 2004. Coal was burned at the inlet of the SAC kiln.

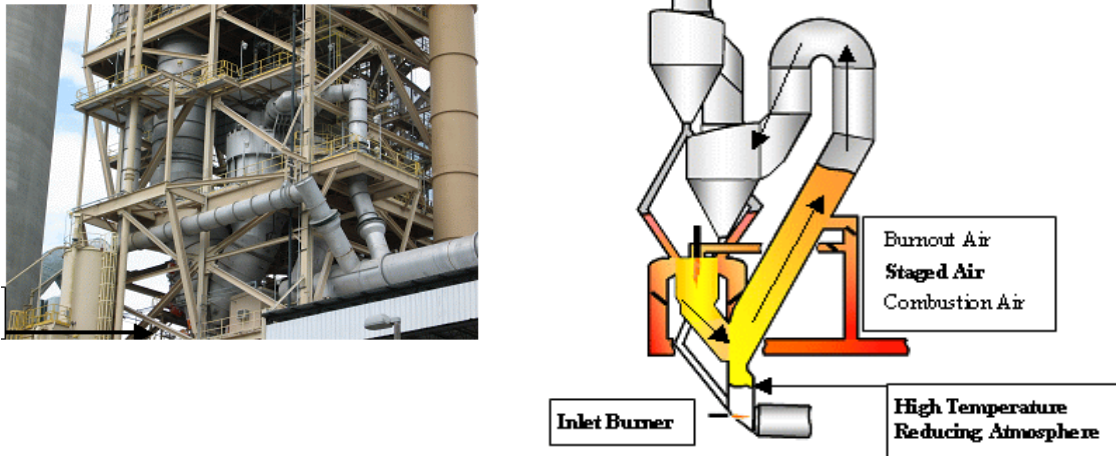

Figure 7-3. Suwannee American, Branford, Florida, Polysius MSC – SCC with kiln inlet burner.⁷

7.2.2 Air and Fuel Staging

A second type of SCC system (Figure 7-4) is an air and fuel staging system, such as the system used at the Florida Rock Industries (FRI) plant in Newberry, FL. This is a Polysius MSC system, horizontally mounted ILC. The calcination burner is mounted horizontally rather than in a separate combustion chamber. Provisions are included for a small burner in the kiln inlet housing. FRI burns tires at the kiln inlet.

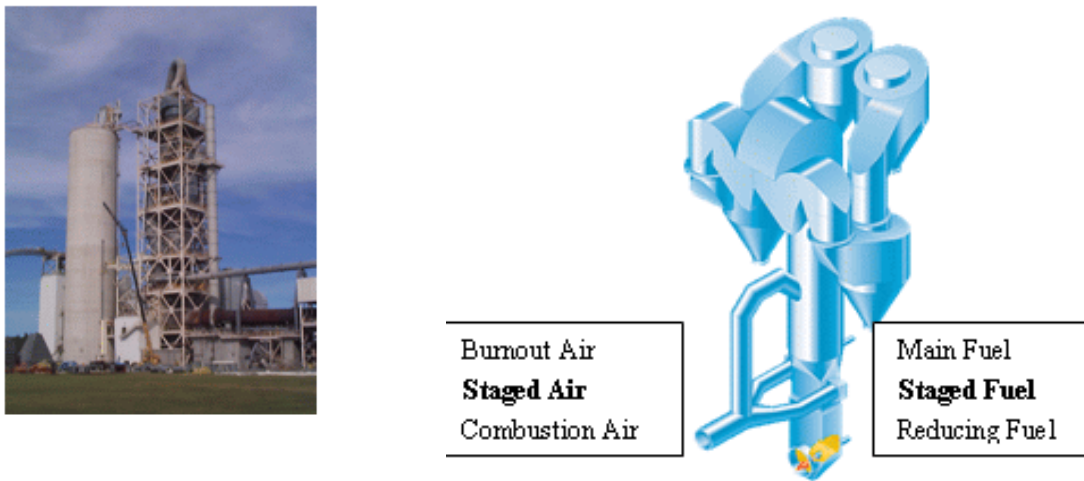

Figure 7-4. Florida Rock Industries, Newberry, Florida, air and fuel staging – SCC.⁷

This FRI kiln has a BACT NO_x emissions limit of 2.45 lb/t of clinker on a 30-day rolling average basis. Data from the first half of 2004 are available and show that typical emissions from the FRI kiln are between 1.5 and 2.5 lb/t of clinker, when tires are burned near the kiln inlet. The 30-day average emissions range from 1.8–2.4 lb/t of clinker, and daily averages range from 1.0–3.7 lb/t of clinker. According to FRI, higher values near 3 lb/t of clinker are observed on days

when tires were not available, which verifies that fuel burning at the kiln inlet and inducing high temperature in the reducing zone can lower NO_x emissions.

7.2.3 Sequenced Fuel and Air

A third type of SCC system (Figure 7-5) is a sequenced fuel and air introduction system, such as the system used at the Titan America plant in Medley, FL. This is a low NO_x ILC. All fuel is fired in a reducing atmosphere near the kiln inlet, and tertiary air is supplied in the lower part of the calciner. Raw meal is split and introduced at different sections of the calciner. Effective SCC designs typically incorporate meal staging for numerous reasons. One key reason is to take advantage of the catalytically enhanced dissociation in the preheater of NO formed in the kiln. Another important reason is as a temperature-control strategy.

This type of calciner does not stage fuel or air, but instead injects all calciner fuel at the bottom of the calciner, before the kiln inlet. All tertiary air is introduced at a single point just above the fuel. A high-temperature reducing zone is created in the kiln riser duct, and the calciner is partially built into the kiln riser. The tertiary air quickly lowers the temperature after the reducing zone, and SO₂ volatilization is limited. This reduces the potential for coating of surfaces with sulfur compounds; thus, coating and plugging are not a problem.

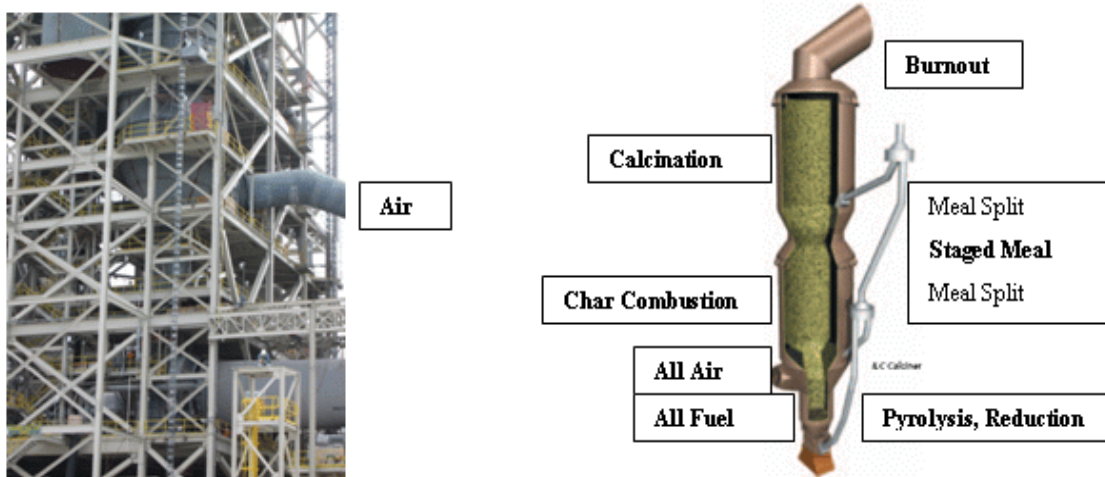

Figure 7-5. Titan America, Medley, Florida, sequenced fuel and air – SCC.⁷

Compliance tests at the new 250 t/hr Titan America kiln showed NO_x and CO emissions at 2.0 and 0.5 lb/t of clinker, respectively. This calciner is not a true SCC system, i.e., it does not stage fuel (e.g., use two burners in the calciner) or stage air (e.g., use two tertiary air inputs to the calciner). Instead, it depends on the introduction of all calciner fuel into a reducing atmosphere near the bottom of the calciner (not actually at the kiln inlet), followed by the introduction of all tertiary air at a single level just above the fuel introduction point.

Averaged over the long term, a well-operated MSC plant under reducing conditions in the calciner can achieve NO_x emissions at 2.3 - 2.5 lb/t of clinker. Staging can involve either the staging of fuel combustion, combustion air, or both. The basic MSC system operating under oxidizing conditions throughout will result in NO_x emissions of about 3.5 – 4.0 lb/t of clinker.⁷

The MSC system can be operated with combustion at various points given the system's fuel-rich conditions. If a kiln inlet burner is used or if tire-derived fuel is fired as supplemental fuel at kiln inlet, combustion can occur with sub-stoichiometric combustion air. This creates a reducing atmosphere around 1,000–1,100 °C (1,830–2,010 °F). Under these high-temperature reducing conditions, a good portion of NO_x generated in the kiln is converted to N₂, thereby reducing NO_x emissions. This concept is similar to reburning.

7.3 SUMMARY OF SCC NO_x PERFORMANCE

Table 7-2 is from a Canadian report agency and summarizes information obtained on several U.S. cement plants and one Canadian plant. Most of the data represents permit data; however, emission test data is provided for a few plants. These emissions data reflect the results of using multiple NO_x controls, including MSC, process controls and LNBs, with emissions ranging from 0.6–1.65 - kg/mt (1.2–3.2 lb/t of clinker). The average of the emissions of the 11 U.S. kilns that have only process controls, LNBs, and MSC is 1.35 kg/mt (2.7 lb/t of clinker). Several other plants use these and other controls.

Table 7-2. NO_x Emissions Performance of Selected Cement Plants⁵

Plant	Location	Year Operation	Emission Factor (kg/tonne)	Concentration (mg/Nm ³) ⁺	Control Method
Ash Grove Cement ⁽¹⁾	Durkee, OR	1998	1.8	1,070	multi-stage combustion; process control; low NO _x burner; burns whole tires in kiln
CEMEX ⁽²⁾	Brookesville, FL	2000	1.8/1.5	(750/620)	multi-stage combustion; process control; low NO _x burner
CEMEX ⁽³⁾	Victorville, CA	2000	1.4	(580)	"
GCC Rio Grande ⁽⁴⁾	Pueblo, CO	2000	1.15	(480)	"
Giant Cement ⁽⁵⁾	Harleysville, SC	2003	1.4	(580)	"
Florida Rock Industries ⁽⁶⁾	Newberry, FL	1999	1.4	(580)	"
Hanson Permanente ⁽⁷⁾	Cupertino, CA	1980	1.1	(460)	"
Hercules Cement ⁽⁸⁾	Stockerton, PA	?	1.5	(620)	and NH ₃ injection
Holcim ⁽⁹⁾	Florence, CO	2000	1.65	1,070	"
Holcim ⁽¹⁰⁾	Midlothian, TX	1997/2001	1.85/0.6	630 @ stack O ₂	tire chips burned in precalciner
Mitsubishi ⁽¹¹⁾	Cushenberry, CA	1995	1.0 – 1.25	(420-520)	40% reduction attributed to biosolids injection
RMC Lonestar ⁽¹²⁾	Davenport, CA	1989	1.0-1.25 24-h ave.	(420-520)	"
Suwanee American ⁽¹³⁾	Branford, FL	2000	1.45	(600)	"
Tarmac America ⁽¹⁴⁾	Miami, FL	2000	1.19 12-month	(500)	"
Texas Industries Inc. ⁽¹⁵⁾	Midlothian, TX	new kiln line 2001	1.4	(580)	and CemStar®
Texas Industries Inc. ⁽¹⁶⁾	Riverside, CA	Under construction	1.4	1020 @7%O ₂	"
Lafarge Canada ⁽¹⁷⁾	Richmond, BC	1999	0.6-1.2	360-610	"

⁺ Concentration data in brackets was derived from the emission factor using 2,400 Nm³ of kiln gas/t clinker (25°C, 101.3 kPa, 11% O₂, dry).

(1) Emission factor is from the Title V Permit 01-0029, dated 2001; the emission concentration of 560 ppmv (dry standard conditions) is from communication with Mark Bailey, Oregon Department of Environmental Quality

(2) Linero, Alvaro A. *What's Up with Cement Plant Permitting?*, paper # 884 presented at AWMA Conference, 2001

(3) Mojave Desert Air Quality Management District. *Engineering Evaluation for Modification of a Major Facility*, New Source Review, Southdown California Cement LLC, June 10, 1999

(4) Environment Canada communication with Ram Seetharam, Colorado Department of Public Health and Environment, July 10, 2003

(5) South Carolina Dept of Health and Environmental Control, Part 70 Air Quality Permit, April 2003

(6) Linero, Alvaro A. *What's Up with Cement Plant Permitting?*, paper # 884 presented at AWMA Conference, 2001

(7) Environment Canada communication with Lee Colver, Hanson Permanente Cement Inc. July 18, 2003

(8) Environment Canada Communication with Mark J. Wejkszner, Pennsylvania Department of Environmental Protection, July 22, 2003

(9) Environment Canada communication with Ram Seetharam, Colorado Dept. of Public Health and Environment, July 10, 2003

(10) Linero, Alvaro A. *What's Up with Cement Plant Permitting?*, presented at AWMA Conference in 2001. Emission concentration (about 240 ppmvd) is from stack tests in 2000. The emission factor of 0.6 kg NO_x/kg was a commitment by Holcim during the permitting process as a long-term NO_x performance. Holcim later stated this was an error. A permit amendment was in process as of July, 2003 that indicated a NO_x emission factor of about 1.4 kg/t for each kiln line.

(11) Environment Canada communication with M. Mizuno, Mitsubishi Materials Corporation, Japan, June 26, 2003; communication of August 20, 2003 with Alan De Salvo, Monterey Unified Air Pollution Control District provided 1998 actual emissions of 1,750 tons NO_x and emission factor of 2.25 lbs NO_x/ton.

(12) Monterey Bay Unified Air Pollution Control District, RMC Lonestar – Davenport Plant, CA, Permit No. TV16-01, Expiration Date: 12/31/03; 24-hour rolling average for NO_x limit.

(13) Linero, Alvaro A. *What's Up with Cement Plant Permitting?*, paper # 884 presented at AWMA Conference in 2001

(14) Linero, Alvaro A. *What's Up with Cement Plant Permitting?*, paper # 884 presented at AWMA Conference in 2001; 12-month rolling ave.

(15) Emission factor is from Emissions Tutorial sponsored by IEEE-IAS/PCA at Cement Technical Conference, May 4-9, 2003, Dallas, Texas.

(16) Mojave Desert Air Quality Management District. *Engineering Evaluation*, TXI Riverside Cement, August 5, 1999

(17) Concentration is from stack sampling over 1999- 2001; emission factor is calculated from clinker production during stack test.

A European study indicates that most current European standards (200–500 mg/Nm³ [1.0–2.4 lb/t of clinker]) can be met by MSC systems manufactured by Polysius. Another European reference states that there is a 10–50% reduction attributable to SCC that achieves emission levels < 500–1000 mg/m³ (< 2.4–4.8 lb/t of clinker).⁹

Table 7-3 summarizes the level of performance expected from SCC with other NO_x controls (primarily combustion and process controls) in place (e.g., LNB in kiln and process controls). As shown in this table, the NO_x level varies considerably from 1.0–4.8 lb/t of clinker. The average of these NO_x levels (excluding those kilns that burn tires and the reported 1.0 lb/t, which is considered an outlier) is 2.7 lb/t of clinker.

Table 7-3. Summary of NO_x Performance of SCC

Source/Location	NO _x Uncontrolled (lb/t)	NO _x Controlled (lb/t)	Efficiency
11 US kilns(from Table 7-2)	NA	2.2–3.3 (avg- 2.7)	NA
ECRA report	NA	2.4–4.8	NA
Florida Rock	3.5	3.0 -w/o tires; 2.0-tires	17% -w/otires; 43%-tires
Suwannee American	NA	2.4	NA
Titan American	NA	2.0	NA
Lone Star	2.8	1.8	35%
American Cement	NA	2.3–2.6 (reducing); 3.5–4.0 (oxidizing)	NA
European Report	NA	1.0–2.4	NA

7.4 LIMITATIONS OF MSC – HIGH SULFUR

In kiln systems that have a process mix with a high sulfur to alkali molar ratio, the volatility of sulfur increases due to the strong reducing conditions of MSC and relatively low oxygen content in the system. Operationally, this increase causes severe preheater plugging to occur due to the significant sulfur deposition associated with MSC operation. The required conditions needed for optimum MSC operation (low excess oxygen) conflict with the goal of preventing sulfur deposition and minimizing operational problems. Thus, a high sulfur/alkali molar feed ratio prevents the achievement of maximum NO_x reduction using MSC.¹⁰

7.5 REFERENCES

1. Tokheim, L.-A. *The Impact of Staged Combustion on the Operation of a Precalciner Cement Kiln*. Telemark College, Porsgrumm, Norway. Available at [www.cement.org/dnld/Staged percent20 Combustion percent20Dissertation.pdf](http://www.cement.org/dnld/Staged%20Combustion%20Dissertation.pdf).
2. Florida Department of Environmental Resources. *BACT Determination – Suwannee American Cement, Branford Florida*. Air NSR/PSD Construction Permits. Available at <http://www.dep.state.fl.us/Air/permitting/construction/suwannee.htm>. Accessed March 6, 2007.
3. Email transmission from A. Linero, Florida Department of Environmental Protection, B. Neuffer, U.S. Environmental Protection Agency. *Cement Kilns – SNCR*. January 6, 2005.

4. Hoenig, V. *NO_x Reduction and Burnout Optimization Using Staged Combustion Rechnology*. Research Institute of the Cement Industry (Dusseldorf). Seminar S04-05 11/3–4/04, Bernburg.
5. Environment Canada. *Foundation Report of the Cement Manufacturing Sector*. Draft #1. Prepared by Minerals and Metals Brand, Pollution Prevention Directorate. June 18, 2004.
6. VDZ (German Cement Works Association). Environmental protection in cement manufacture. Chapter II in *VDZ Activity Report 2003–2005*. Figure II-15, p. 55. 2005.
7. Linero, A. *SNCR NO_x at US Cement Plants. Is SCR Close Behind?* Paper #638 presented at the AWMA Annual Conference. June 2005.
8. Florida Department of Environmental Protection. *Report in Support of an Application for a PSD Construction Permit Review – Natural Resources of Central Florida, Inc.* American Cement Company, Sumterville, FL. October 4, 2005. pp. 93–99. Available at www.dep.state.fl.us/Air/permitting/construction/american/
9. Erpelding, R. *NO_x Reduction with the MSC/SNCR combination: Chances and Risks*. Krupp Polysius AG. Undated.
10. Florida Department of Environmental Protection. *Technical Evaluation, Preliminary Determination, Draft BACT Determination, Sumter Cement Company*. December 21, 2005. Available at www.dep.state.fl.us/Air/permitting/construction/american/TEPD358.pdf.

8.0 SELECTIVE NONCATALYTIC REDUCTION (SNCR)

8.1 BASIS OF SNCR

The SNCR process is basically the injection of ammonia in the form of ammonia water or urea in the flue-gas at a suitable temperature. An aqueous ammonia solution is the reagent that has been most often used for cement kilns, and experience indicates that an ammonia solution is most effective for PH/PC cement kiln applications.^{1,2,3} Other reagent alternatives include anhydrous ammonia (injected as a gas), urea solutions, and ammonium sulfate solutions.

An SNCR system's performance depends on temperature, residence time, turbulence, oxygen content, and a number of factors specific to the given gas stream. These factors are discussed later in this report. SNCR removes NO_x (90–95% of NO_x in flue gas is NO) by a two-step process, as follows:

- Ammonia reacts with available hydroxyl radicals to form amine radicals and water:



- Amine radicals combine with nitrogen oxides to form nitrogen and water:

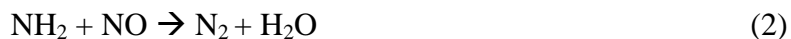

These 2 steps are typically expressed as follows:

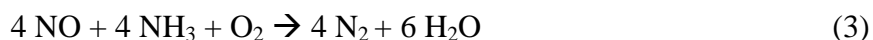

and



Equation 3 is the predominant reaction because 90–95% of NO_x in flue gas is NO.⁴

These equations suggest that SNCR will function best in an oxidizing atmosphere, whereas the following equation shows that in a reducing atmosphere, CO competes with ammonia for available OH radicals, thus inhibiting reaction 1.



8.2 EQUIPMENT NEEDED FOR SNCR⁵

Onsite storage vessels and a truck-unloading stand are required to receive the delivery of ammonia or urea to a plant. Ammonia and urea may be received as a liquid solution or may be mixed with water onsite to the desired solution concentration (typically 10 -25% ammonia/urea). If mixed onsite, additional water storage, purification, pumping, and mixing equipment is required. The purification system removes minerals from the water that may cause plugging of the ammonia delivery system. Insulation and heating of urea lines is required to prevent the urea from crystallizing and/or the water solution from freezing. Ammonia, in the form of anhydrous

ammonia gas, must be stored in cylinders, and all forms of ammonia have specific transportation, handling, and storage requirements.

The ammonia solution is pumped through pipes and delivered into the calciner or preheater tower through an injection lance. This injection process requires a pump, pump skid, and ammonia-flow control unit. The exact location and number of injection points will differ from one system to the next and are optimized through testing.

Measurement equipment is necessary to maintain the appropriate ammonia feed rate. Additional monitoring equipment is required to record the amount of NO_x and ammonia slip in the gases exiting the SNCR system to adjust the amount of ammonia entering the system. Temperature monitors are also required to make sure that the ammonia is delivered to the correct location.

8.3 APPROPRIATE TEMPERATURE FOR SNCR

As mentioned in Section 8.1, the temperature window for the SNCR reactions is critical.² Table 8-1 shows the acceptable ranges from various references. At higher temperatures, ammonia will react with oxygen, thereby increasing NO_x concentrations. At lower temperatures, the rates of NO_x reduction reactions become too slow, resulting in excessive ammonia slip or the excessive build-up of ammonia in raw materials. The range is 870–1,100 °C (1,600–2,000 °F). The performance of urea and ammonia at various temperatures is displayed in Figure 8-1, which shows that ammonia has a slightly higher efficiency than urea at temperatures between 760–930 °C (1,400–1,700 °F) and urea has slightly higher efficiency between 950–1,040 °C (1,750–1,900 °F).⁵

Table 8-1. Suitable Temperatures for SNCR

Reference	Ammonia/Urea	Gas Temp (°C)	Gas Temp (°F)
EC/R Report ⁷	Urea	870–1,090	1,600–2,000
Mussati ⁵	Urea	900–1,150	1,650–2,100
Florida Rock test report ¹²	Urea	1,000	1,830
EC/R Report ⁷	Ammonia	920–980	1,660–1,840
Mussati ⁵	Ammonia	870–1,100	1,600–2,000
Florida Rock test report ¹²	Ammonia	950	1,750
Technical evaluation – Suwanee ⁴²	Both	850–1,050	1,560–1,920
NESCAUM ⁸	Both	870–1,100	1,600–2,000
Draft 1 fond report ¹	Both	800–1,100	1,470–2,000
Penta report ⁹	Both	900–1,000	1,650–1,830

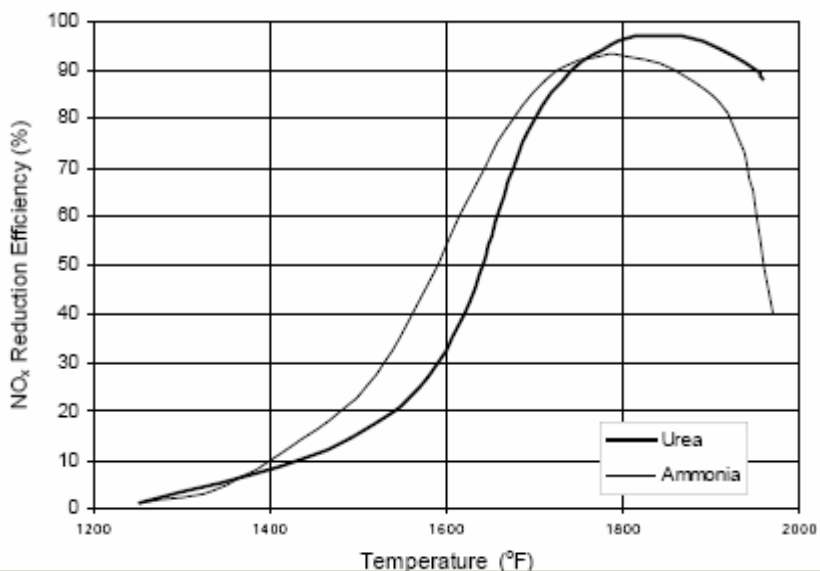

Figure 8-1. Ammonia and urea reduction at various temperatures.⁵

8.3.1 Location of Suitable Temperature

For PH/PC kiln systems, the likely locations for suitable temperatures are at the cooler end of the rotating kiln, in the riser duct, and in the lower section of the cyclone preheater tower.⁷

The major cement kiln manufacturer, Polysius, believes there are three possible SNCR injection points (refer to Figure 8-2 for the locations of injection points a, b, and c):⁸

- a. Combustion zone in the part of calciner operated under reducing conditions (930–990 °C [1,710–1,810 °F]). This location is most ideal as far as temperature is concerned.
- b. Oxidation zone under the upper air inlet before the deflection chamber (850–890 °C [1,560–1,630 °F]).
- c. Area after the deflection chamber before the inlet to the bottom cyclone stage.

Optional points for adding SNCR reducing agent

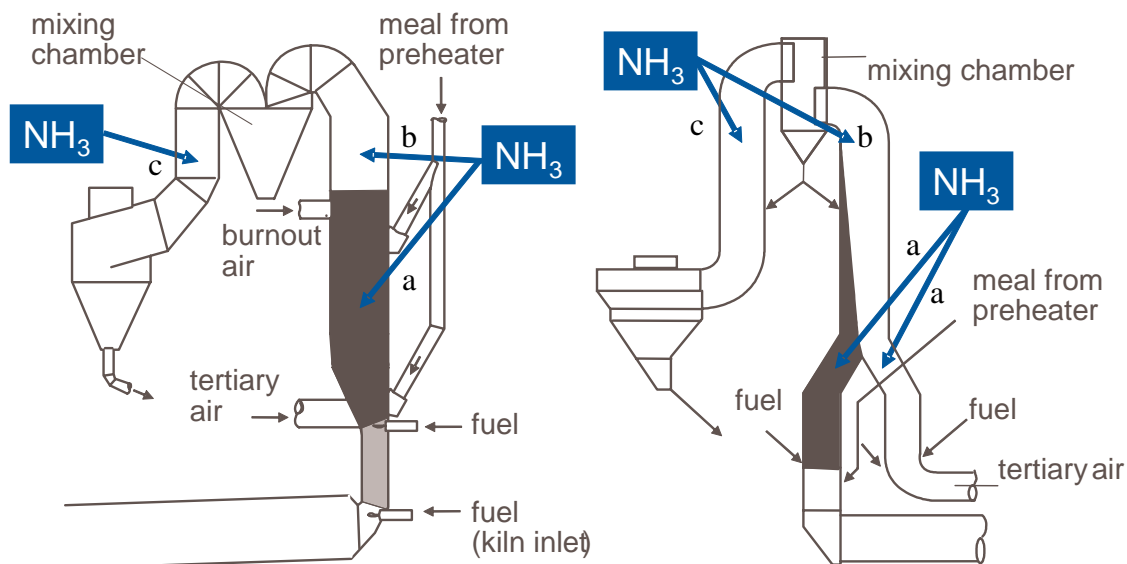

Figure 8-2. Possible SNCR injection points.⁸

8.4 OTHER FACTORS AFFECTING SNCR

Other important design and operational factors that affect NO_x reduction by an SNCR system are the following:⁹

- Residence time available in optimum temperature range
- Degree of mixing between injected reagent and combustion gases
- Uncontrolled NO_x concentration level
- Molar ratio of injected reagent to uncontrolled NO_x .

8.4.1 Residence Time

Residence time is an important parameter for SNCR performance. Time is required for the following:

- Mixing of injected ammonia solutions/urea with flue gas
- Evaporation of water
- Decomposition of NH_3 to NH_2 and free radicals
- NO_x reduction reaction chemistry.

Increasing the residence time available for mass transfer and chemical reactions generally increases the NO_x removal. In addition, as the temperature window is lowered, greater residence time is needed to achieve the same NO_x reduction level. Residence time can vary from 0.001 to 10 seconds; however, the gain in performance for residence times greater than 0.5 seconds is generally minimal.¹⁰ For cement kilns, one source stated that the required residence time is 0.5–1.0 seconds.¹⁰ Figure 8-3 below shows the increased performance of SNCR as the residence time is increased.

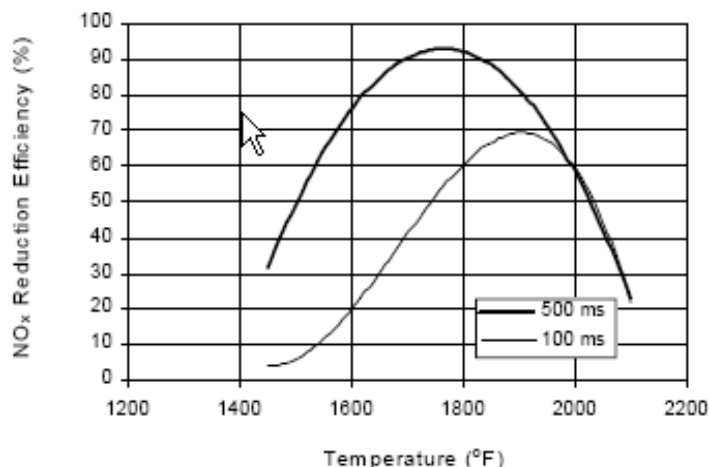

Figure 8-3. NO_x reduction and residence time.¹⁰

8.4.2 Degree of Mixing⁹

For the reduction reaction to occur, the reagent must be dispersed and mixed throughout the flue gas so that there can be contact between the NO_x and the reagent. Dispersion must occur rapidly due to the volatility of the ammonia solution. Mixing is performed by the injection system. Injectors (called spray nozzles or lances) atomize the reagent and control the spray angle, velocity, and direction of the injected reagent. To assist in dispersion of aqueous urea, the reagent is atomized into droplets by specially designed nozzles that optimize droplet size and distribution. The location and number of injection points may affect the success of NO_x reduction, and these variables should be tested for each kiln system.

Inadequate mixing can be improved by the following:

- Increasing energy imparted to droplets
- Increasing the number of injectors (between one to six nozzles at gas riser)
- Increasing the number of injection zones
- Modifying the atomizer nozzle design to improve the solution droplet size, distribution, spray angle, and direction

8.4.3 Uncontrolled NO_x

Reaction kinetics decrease as the concentration of reactants decreases. This is due to thermodynamic considerations that limit the reduction process at low NO_x concentrations. For lower NO_x inlet concentrations, the optimum temperature for reaction is lower; hence, the percent NO_x reduction is lower. Figure 8-4 shows the effect of three different NO_x concentrations on the reduction efficiency. At 980 °C (1,800 °F), 54% efficiency is obtained at a 200 ppm concentration; 41% efficiency at 70 ppm; and 12% at 30 ppm.¹

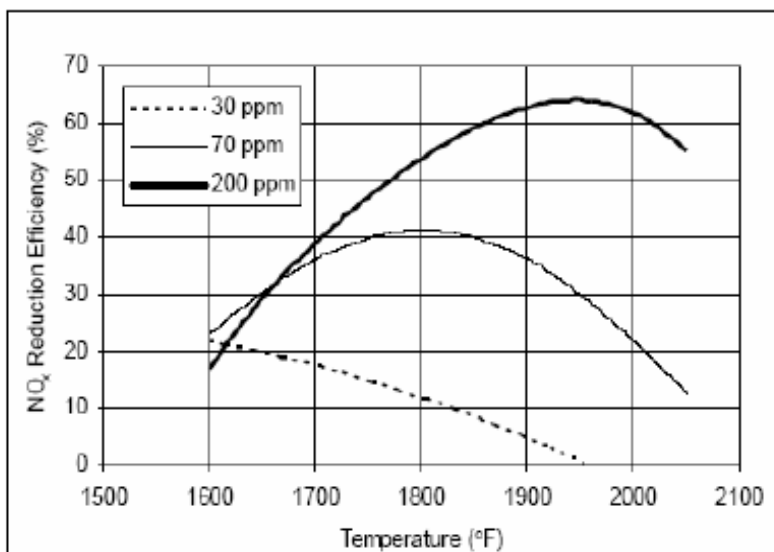

Figure 8-4. Effect of initial NO_x level on reduction efficiency.¹¹

8.4.4 Normalized Stoichiometric Ratio (NSR)

As applied to NO_x controls, NSR is the ratio of moles of ammonia/urea applied to moles of NO_x in the flue gas. In theory, two moles of NO_x can be removed by one mole of urea or two moles of ammonia. However, in practice, more than the theoretical amount of reagent is needed to obtain a specific level of NO_x reduction. This is due to the complexity of the actual chemical reactions involving NO_x and the injected reagent, as well as the mixing limitations between the reagent and flue gas.

One source estimates that NO_x emissions are reduced between 60–80% at an ammonia injection rate of NH₃:NO_x of 1–1.5. Using a molar ratio of 0.5, NO_x reductions are approximately 40%.⁷ Figure 8-5 shows the effects of varying the Normalized Stoichiometric Ratio (NSR) at three European cement kilns. At an NSR of 1.0, NO_x reductions varied from 42–70%.

NO_x reduction depending on NH₃/NO molar ratio for precalciner kilns

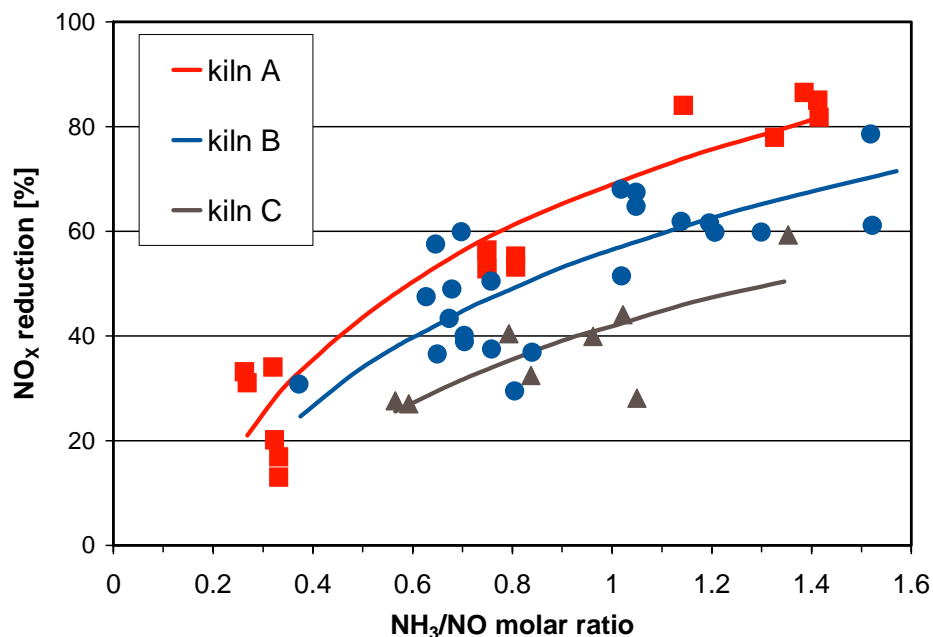

source: Krupp Polysius AG(ZKG 7/2001)

Figure 8-5. Impact of Normalized Stoichiometric Ratio on NO_x reduction.⁸

8.5 POTENTIAL PROBLEMS WITH SNCR

Not all of the ammonia injected into the SNCR system reacts with NO_x, and the unreacted ammonia is called ammonia slip. Ammonia in the flue gas stream can have a detectable odor at levels of 5 ppm or greater. Health concerns can occur at ammonia slip levels of 25 ppm or greater. When burning fuels containing chlorine compounds, stack plume visibility problems can occur due to the formation of ammonium chlorides. Limits on ammonia slip are imposed by permits or design requirements. These limits place a constraint on the NO_x reduction achieved by an SNCR system.

In addition, operating experience identified several concerns with the build up of ammonium bisulfite scale when burning sulfur-containing fuels.² Sulfide or elemental sulfur contained in the fuels or raw materials may be roasted or oxidized to SO₂ in areas of pyroprocessing system where sufficient oxygen is present and the material temperature is 300–600 °C (570–1,100 °F). For some cement plants, SO₂ is not a problem. Uncontrolled SO₂ emissions are only about 0.10 lb/t of clinker and less than 100 t/yr at Florida's PH/PC kilns because there are minute amounts of sulfur in most of the available limestone. Uncontrolled SO₂ can be as much as two orders of magnitude greater when pyritic sulfur is present in raw materials. Unreacted ammonia from the SNCR process or from raw materials reacts with SO₂ and SO₃ at temperatures prevalent in the upper preheater, pollution control equipment, and outside the stack. Ammonium bisulfate, ammonium sulfate, and ammonium bisulfite may be formed.¹²

When the kiln system is operating with the raw mill on line, the compounds condense and are returned to the feed system and preheater, where they are revaporized. Subsequently, these compounds condense in the raw mill system. When the raw mill is taken off line, the volatile salts are no longer captured in the raw mill and move to the particulate matter (PM) collection device (baghouse or electrostatic precipitator [ESP]). Because the PM control does not capture these new, high concentrations as efficiently, the plume becomes highly visible. When the raw mill is put back into operation, the plume is not visible. This cycle continues indefinitely. It would seem that a filter cake in a baghouse would even out these emissions more so than an ESP, so it is not a foregone conclusion that the plume will be highly visible.

If the plant has a persistent, detached plume due to ammonium sulfate, it is necessary to eliminate ammonia or sulfur dioxide. The obvious method for this is to minimize ammonia use when SO₂ emissions are likely.

Operating the raw mill also promotes SO₂ removal by limestone scrubbing under humid conditions, due in part to the freshly generated limestone surface produced by grinding. Some of the SO₂ generated in the top preheater stages is also scrubbed out by small amounts of free CaO that are carried back from hotter zones by combustion flue gases.

Another SO₂ removal technique is to extend the inherent self-scrubbing by CaO that occurs in the calciner to the upper sections of the preheater, where pyrite-derived SO₂ is evolved. This involves conveyance of CaO from the calciner to the upper stages of the preheater, which consists of a cyclone and some ductwork and no moving parts.

If these three SO₂ measures are insufficient, then conventional wet or dry scrubbers can be considered. The Texas Commission on Environmental Quality estimated that the TXI Midlothian scrubber cost \$13 million. SO₂ emissions were permitted at 1.33 lb/t of clinker, but it is not certain whether SO₂ emissions are that high. If they are that high and an SNCR system is installed, it might be necessary to limit ammonia slip or to further enhance SO₂ removal to avoid a detached plume.

A very fine suspension of slaked CaO can be introduced into gas-conditioning tower to remove SO₂, particularly when the raw mill is not operating. The droplets react, dry, and are captured by the PM controls, where the excess CaO (from the dried droplets) will continue to remove the remaining SO₂.¹²

8.6 SNCR EXPERIENCE

8.6.1 United States – Early Tests

According to EPA's NO_x ACT reports, there was very limited experience with SNCR at cement kilns; however, two U.S. plants that were tested with SNCR systems and that are mentioned in these reports are discussed below.

8.6.1.1 Ash Grove Cement - Seattle, Washington¹³

A week-long test of a Nahlco Fuel Tech (urea) system at the Ash Grove Cement plant in Seattle, WA, was performed in October 1993. This test was conducted on a 160 tons per hour

(t/hr) 5-stage PH/PC kiln under 10 different operating conditions representing a wide range of fuel firing and excess air conditions. The urea-based system was easily installed at the plant using an existing port and available resources without a plant outage. Plant operation was unaffected during testing. A commercial system should also be easily adapted to plant operations and easily maintained. The NO_x emission limit (422 lb/hr or 2.6 lb/t) was maintained under various kiln/calcliner operating conditions.

The urea reagent was injected at three ports at the top of the calciner, three ports halfway up the calciner, and four ports at the bottom of the calciner. During the test, the kiln feed rate was steady at 160 t/hr, and the kiln was fired with natural gas. As a result of the injections, NO_x emissions were reduced from 350–600 lb/hr to less than 100 lb/hr. The NO_x reduction was greater than 80% for most cases, and chemical utilization of urea was greater than 50%. These excellent results were attributed to a high degree of mixing and a long residence time at an appropriate temperature in the preheater tower. The average ammonia slip was 4 ppm above baseline at an NSR of 1.

When firing gas into the kiln and coal in the calciner, uncontrolled NO_x emissions averaged 2.8 lb/t of material input. When gas was fired in both units, uncontrolled NO_x emissions were 2.9 lb/t of clinker. Based on limited short-term data using stabilized urea, NO_x was reduced by ~27% at an NSR of 0.5 and by ~55% at an NSR of 1.0.¹⁴ At an NSR of 1.5, the NO_x reduction was as high as 80%, and chemical utilizations were higher than 50%. At an NSR of 2, a 90% reduction of NO_x was obtained. The EC/R report indicates that under 10 different operating conditions at this same kiln, NO_x was reduced from 3.5–6.0 lb/t of clinker to less than 1 lb/t clinker.⁷

SO₂ and CO were unchanged from baseline levels at an NSR < 0.7. At a higher NSR, these emissions also remained near baseline levels when the preheater oxygen concentration was > 2.3%. However, both SO₂ and CO increased slightly with increased chemical injection rates at lower oxygen. Ammonia at the exit of the preheater was erratic, ranging from 6 ppm under baseline to 10 ppm at an NSR of 1.

8.6.1.2 LaFarge – Davenport, Iowa

A NO_xOut® system (urea) was tested in October 1998 at LaFarge's plant in Davenport, IO. Much lower NO_x reductions were obtained (10–20% from uncontrolled emissions of 350 lb/hr) at the LaFarge plant, the reasons for which are presented below.¹⁵

The LaFarge plant is unusual due to the high proportion of heat released in the plant's calciner. Most PH/PC kilns supply 50% of heat input to the calciner. Unlike the Ash Grove plant, where only 5–10% of heat input is added at the calciner, 70% heat input is added at the calciner at the LaFarge plant. This difference affects the gas temperature in the calciner and the gas-retention time in the 860–1,090 °C (1,600–2,000 °F) range where SNCR is effective. The flue gas in the Ash Grove system stayed within this range for a longer time, and the gas retention time in the calciner was 2.7 seconds compared to 1.95 seconds at the LaFarge plant. The LaFarge unit operates at 815–920 °C (1,500–1,700 °F), and Ash Grove operates at 840–1,130 °C (1,540–2,070 °F); thus, the Ash Grove unit has a larger window within this range.

In addition, a significant portion (40–60%) of the kiln flue gas at LaFarge is bypassed prior to the calciner; therefore, roughly half of the kiln exhaust gas is not treated by SNCR. Raw material at the LaFarge plant is highly alkaline (e.g., sodium, potassium) compared to the material processed at the Ash Grove plant. The LaFarge alkali bypass provides the ability to control alkali content of the clinker product; thus, anticipated SNCR control should be much less than 30–70% because roughly 50% of the kiln’s flue gas was not treated by SNCR. The gas exit temperature of the bypass gas is 920 °C (1,700 °F), but is immediately quenched by adding dilution air to 430–780 °C (800–900 °F). There is not sufficient time for the addition of SNCR to this gas stream (the alkali bypass stream). Data during the Fuel Tech tests in October 1998 indicate that approximately one-third of uncontrolled stack emissions are from the bypass.

Another reason why SNCR was not effective at La Farge was due to the PH/PC temperature profiles.¹⁶ No section of the calciner had an ideal temperature profile for SNCR. The reagent injection is at the top of the preheater (after the Stage 4 cyclone), where the temperature is around 890 °C (1,640 °F). The temperature drops by 90–120 °C (200–250 °F) over the next 1.3 seconds as gases pass through the Stage 4 cyclone. Thus, the temperature is marginally within the SNCR window and there is a slight NO_x reduction. Ammonia slip was 14 ppm from the 5–6 ppm baseline. Flue gases have cooled well below the SNCR temperature window; therefore, no reduction was found. Ammonia slip was 47–52 ppm.¹⁷ The optimal SNCR temperature window is 860–1,090 °C (1,600–2,000 °F); however, this window only appears in the upper calciner/lower Stage 4 cyclone zone of the LaFarge kiln system. The temperature in this zone of the LaFarge kiln system ranges from 860–920 °C (1,600–1,700 °F), with a residence time of less than two seconds. At LaFarge, the temperature of flue gas in the riser between the kiln exit and the bottom of calciner is 815 +/-10 °C (1,500+/-50 °F). The peak temperature in the calciner is 920 °C (1,700 °F), and the temperature at the exit of calciner is 890 °C (1,640 °F). The gas residence time in the calciner is 1.95 seconds. Flue gases exit the calciner and enter the Stage 4 cyclone preheater (taking 1.3 seconds).¹⁷

By comparison, at Ash Grove, the combustion gas from the kiln enters the bottom of the calciner at 1,120 °C (2,070 °F). The gas temperature at the top of the calciner is 830 °C (1,540 °F). The horizontal temperature profiles were essentially flat, with less than a 8 °C (15 °F) variation across the preheater cross section. The estimated residence time in the calciner is 2.7 seconds. After leaving the kiln, the maximum temperature reached by the flue gas is 920 °C (1,700 °F) at the middle of the calciner, very near the combustion zone. Results for the Ash Grove and LaFarge pilot tests are summarized in Table 8-2.

Table 8-2. Summary of Pilot Test Results for Ash Grove and LaFarge

Parameter	Ash Grove, Seattle, WA	LaFarge, Davenport, IA
NO _x Reduction (%)	27, 55, 80 (at NSR of 0.5, 1.0, 1.5, respectively)	10-20
Heat input to precalciner (%)	5-10	70
Alkali bypass (%)	0	40-60
Gas residence time for SNCR reaction (sec)	2.7	1.95

8.6.2 U.S. Plants Presently Using or Installing SNCR

8.6.2.1 Hercules Cement – Stockertown, PA (Using SNCR)

The oldest existing, full-scale SNCR installation on a cement kiln presently operating in the United States is located at Hercules Cement in Stockertown, PA. This SNCR system uses a 19% ammonium hydroxide solution (AHS) and was installed in 2001 on kiln #3 (a PH/PC kiln). Kiln #3, also equipped with LNB, accounts for 60% of the cement production at this plant.¹⁸

The Hercules Cement SNCR system was installed to comply with RACT levels, and NO_x reductions of 25% (300 ppm) have been achieved using this system. The reduction rates of 11.5% are sustainable, and the system has no impact on clinker production.¹⁹

Tests in 2003 show ammonia emissions to be 13 ppmdv (28 ppmvd @ 7% oxygen). If a good spot for injecting the AHS into Kiln #1 can be found, an overall reduction of 40–50% at stack may be seen. The annual cost for AHS is \$20,000-35,000.¹⁸

The ammonia injection for the Hercules Cement PH/PC kiln is near the bottom of the calciner rather than at the 180 degree bend before the bottom cyclone. This location is better because of its low CO and maximum oxygen, because the ammonia does not have to compete with CO for available OH radicals. SNCR performance might also be limited by the possibility of a detached plume if there are pyrites in the raw material.²⁰

8.6.2.2 St Mary's Cement – Charlevoix, MI (Using SNCR)

An SNCR system was temporarily installed on the PH/PC kiln system at the St. Mary's Cement plant in Charlevoix, MI, and pilot tests were conducted in April of 2005. The SNCR system was utilized through the 2005 ozone season. The plant is in the process of permanently installing an SNCR (urea) system. According to State of Michigan personnel, the permanent SNCR system is being installed to comply with Michigan NO_x Rule 801, which sets a limit of 6.5 lb/t of clinker (30-day rolling average) during the ozone season.^{20, 21} The kiln was originally a long wet kiln that was modified to a PH/PC kiln in 1977.

Daily averages for the period May 1–September 30, 2005, were obtained from the State of Michigan. The 30-day rolling averages beginning May 30, 2005, range from 4.41–6.38 lb/t of clinker for this period. Clinker production varied between 716 and 4,516 t/day, and there were 11 days during this period when the kiln did not operate. Most days, the production range for clinker varied and 3,800 and 4,500 t/day.²²

According to plant personnel, the St. Mary's plant uses a 40% urea solution. The kiln has a lot of up and down operations and operates typically at about 70–80% capacity during the ozone season. The calciner and kiln are both permitted to burn coal, and there is a test trial permit for the firing of petroleum coke. This trial will dictate what percentage of coke will be burned in the system. There is also a 10–30% alkali bypass on the St. Mary's system. The urea solution is currently injected above the kiln feed shelf and before the calciner. Other locations for injections were tested, such as after the calciner and at the upper stage and entrance of the calciner, but optimum efficiency was obtained at the present location.²³

8.6.2.3 Cemex - Brooksville, Florida (Using SNCR)²⁴

Cemex has installed an SNCR system on two existing preheater kilns (not PH/PC kilns) in Brooksville, FL. An SNCR system is presently operating on one of the two kilns, and the other kiln will start operating SNCR after obtaining a permit to test tires and petroleum coke as fuels. The Cemex SNCR system uses a 19% ammonia solution with one injection nozzle at the kiln inlet, where the optimum temperature for ammonia (850–1,150 °C [1,550–2,100 °F]) is available. The oxygen content is typically 1.5–2.0% at this location. There are also three injection nozzles in the riser duct, but these are not used.

The ammonia solution injection rate for the single injection point can vary from 0–15 liters per minute or up to 0.35 lb-moles of ammonia per minute. Assuming an ammonia utilization rate of 75%, based on other tests in Florida, equates to a potential NO_x reduction of up to 15 lb-moles/hr. A NO_x reduction of about 4–5 lb-moles/hr equates to a NO_x reduction from the present maximum rate of 4.0 lb/t of clinker to the proposed emission rate of 2.0 lb/t of clinker; therefore, there is assurance that the SNCR system is capable of delivering the required ammonia. The molar ratio for this reduction is 0.6–0.7.

Cemex plant operators believe that, even with the potentially greater NO_x emissions during the firing of petroleum coke or coke/coal mixture, there is sufficient ammonia delivery capability with the single injection point to achieve 2.0 lb/t of clinker.

As noted previously, preheater kilns are less fuel efficient than PH/PC kilns. In addition, all fuel is burned at the main kiln burner in a preheater kiln, so a great deal of thermal NO_x is produced. The uncontrolled emission rate for preheater kilns is also higher than for PH/PC kilns as shown in Table 6-1.

8.6.2.4 Holcim, Midlothian, Texas (Using SNCR)^{25–29}

The Holcim plant in Midlothian, TX, operates two PH/PC kiln lines. Line 1 was commissioned in 1987, and Line 2 was commissioned in March 2000. The plant exceeded 1998–99 NO_x permit limits and was therefore required to test SNCR. The permit limit was 1,659 t/yr for the combined kilns.

Line 2 has an LNB in the kiln, an MSC, and provisions for alternative fuels. Line 1 uses alternative fuels, but does not have an LNB or MSC. Wet scrubbers were added to both lines and were predicted to remove 25% of NO_x based on European operations. However, in the United States, most NO_x emissions from cement kilns are NO, so little reduction using this scrubber was obtained.

The SNCR system (using a 19.5% ammonia solution) was tested on both lines in 2005. For both lines, the ammonia solution was injected at the point where the temperature was approximately 900 °C (1,650 °F). For Line 1, the injection location was the riser duct after the calciner and before the bottom-stage cyclone. For Line 2, the selected injection point was on the riser duct after the tertiary air input and before the calciner. These locations were optimal with regard to temperature, retention time, and cross-sectional spray distribution.³¹ The entire airflow was tested at full load conditions and at all operating parameters (e.g., mill-up/down, scrubber-up/down.) The test period was approximately two weeks per line. On a routine basis, Line 1

achieved a 40–45% reduction, and Line 2 achieved a 30–40% reduction. These numbers only establish SNCR “applicable” and “effective” levels. The NO_x reduction was as high as 80%, but at this reduction, there was excessive ammonia slip and pluggage at the preheater.

According to Holcim personnel, full-scale SNCR systems began operating on April 15, 2006, on Lines 1 and 2. The ammonia solution was added at the top of the preheater for Line 1 and at the top of the pyroclone for Line 2.³¹

Table 8-3 summarizes curves prepared on the performance of the SNCR systems for the two Holcim lines. The SNCR testing commenced with a molar ratio of 0.4 and increased. No significant change in CO was observed during the SNCR testing; however, a general increase in ammonia emissions was observed. A plug formed at the top of the Line 1 preheater tower following testing at molar injection rates greater than 1.0. It is unknown if this plugging was directly related to the increase of molar ratio or was a gradual, continuous process of ammonium sulfate and ammonium bisulfate deposition in the preheater tower.

Table 8-3. NO_x Reductions (%) for Lines at Holcim, Midlothian, Texas

Line	NSR- 0.4	NSR- 0.6	NSR- 0.7	NSR- 1.0
1	30	43	47	60*
2	10	28	32	45*

* Sharp increases in NH₃ emissions

The new NO_x permit limits for the combined kilns are 3,738 t/yr and 1,300 lb/hr. During the ozone season (May 1– September 30), NO_x must not exceed 1,564 tons for the combined kilns. Additional SNCR testing will be conducted in 2006 and 2007 and may result in changes to the NO_x permit limits.

8.6.2.5 Holcim – Lee Island, Missouri (Installing SNCR)

Construction of this new Holcim plant began in summer 2006, and the expected completion date is 2008–2009. The annual clinker production capacity of the new plant will be 4.828 million tons, using one PC/PH kiln system.³²

An SNCR system is to be installed as innovative control technology no later than 24 months after the plant commences operation. After the installation of the SNCR system, NO_x emissions on 12-month rolling operation will be less than 1,322.8 lb/hr and 2.4 lb/t of clinker. There will also be a summer season (May 1 to September 30) NO_x emission limit of 1,622 tons. This limit includes 530 t/yr of emission-reduction credits. In no case shall NO_x emissions exceed 1,822 tons of NO_x for the summer season from the ILC and raw mill system.³³

8.6.2.6 Lehigh Portland Cement – Mason City, Iowa (Using SNCR)

An SNCR demonstration test was done on PH/PC kiln #8 at Lehigh Portland Cement in Mason City, IO. Lehigh’s kiln #8 is equipped with LNB and has a capacity of 1,050,000 tons. Other existing controls include an ESP for PM and a scrubber for SO₂. During stable operation,

the SNCR system reduced NO_x emissions by 22%. The molar ratio data used during this test are considered confidential business information.

The SNCR system was required to be installed as BACT in a 2004 prevention of significant deterioration (PSD) permit. The Iowa Department of Natural Resources (DNR) concluded that the plant was capable of installing SNCR as a retrofit technology as part of a major plant upgrade. The precalciner vessel was replaced by a larger vessel, and all of the four stage cyclones were replaced with a larger, more efficient vessel.¹⁶

The SNCR system was installed in late 2005. A 180-day shakedown period has been completed, and compliance was being achieved. The Fuel Tech urea reagent is injected in two locations – two injectors at the crossover duct and five injectors at the top of the calciner. The SCNR system is operated year round.

The NO_x emission limit is 2.85 lb/t of clinker (30-day rolling average), a 25% reduction due to SNCR. Therefore, uncontrolled NO_x is 3.8 lb/t of clinker. In addition, there is a calendar monthly average limit of 5 lb/hr. The calciner burns fuel in substoichiometric conditions.³⁴

8.6.2.7 Drake Cement – Arizona (Installing SNCR)

A proposed Drake Cement plant is expected to be constructed and commence operation in 2008. The nominal capacity of the PH/PC kiln system is 660,000 t/yr. The system will be a rotary kiln, 6-stage preheater, low NO_x calciner with a clinker production of 2,000 t/day. The maximum capacity of the plant will be 83 T of clinker/hr, and the kiln will operate 7,920 hrs/yr. The rotary kiln and calciner will burn coal, which will be less than 0.90 weight percent sulfur. The raw limestone will have a total sulfur content < 0.01 weight percent. Fuel combustion in the calciner will be 50–55% of the total energy demand of the PH/PC kiln system; the energy demand of the rotary kiln will be 45–50%. There will be low sulfur in the raw material. One ton of raw feed material requires 0.0765 tons of coal. Approximately 1.53 tons of raw materials are required to produce one ton of clinker.³⁵

The air permit application submitted in June 2004 proposed an emission limit of 2.3 lb/t of clinker on a 24-hr basis. The controls to be used include LNBS in the kiln, a low NO_x calciner, and MSC. The draft permit issued by the State of Arizona has a BACT limit of 1.95 lb/t of clinker (30-day rolling average).³⁵ For the first 180 days after initial startup of the rotary kiln, the NO_x emission limit will be 2.45 lb/t of clinker on a daily rolling 30-day average. To comply with Class I considerations, the limit is 95 lb/hr on an hourly 24-hr average. Using the maximum production rate of 83 t/hr of clinker, this is equivalent to 1.14 lb/t of clinker vs. 1.25 lb/t clinker by SNCR. This suggests that BACT is not necessarily the lowest limit for NO_x when there are other issues to consider, such as visibility.³⁵

It is expected that the reagent injection (ammonia in an aqueous solution) will be introduced in the space between the calciner and the bottom stage of the preheater, which has a temperature window of 860–980 °C (1,580–1,800 °F).

As described in an Innovative Control Technology analysis, Drake intends to reduce NO_x emissions to 416 t/yr, with a voluntary limit that has been proposed as result of Air Quality

Impact Analysis. Drake also proposes to add SNCR in conjunction with the currently proposed BACT limit.

To meet the voluntarily accepted, modeling-driven limit, Drake plans to optimize SNCR systems and other process and air pollution control equipment to minimize NO_x emissions. If these operations do not reduce NO_x to 416 t/yr, Drake will curtail production to ensure that 416 t/yr is not exceeded during any 12-month period.

With a six-stage PH/PC process and a low NO_x calciner (i.e., offering multistage or stageless combustion and sufficient residence time), the NO_x emission rate is estimated to be 1.9–2.3 lb/t of clinker. According to its Class 1 application, Drake Cement's use of these combustion design features will deliver an emission rate that satisfies BACT requirements. The NO_x concentration leaving the calciner and entering the SNCR will not be as high as plants using current combustion technology. This has the benefit of reducing the additional NO_x reduction by SNCR that is necessary to achieve the proposed emission limit of 95 lb/hr. Therefore, the portion of overall NO_x reduction attributable to SNCR is within current process capabilities with respect to both relative proportion (percent controlled) and absolute magnitude (lb/hr removed).³⁶

Drake has the advantage of incorporating features that will improve SNCR performance as an integral part of the process design rather than retrofitting equipment. It is anticipated that this design effort (which will build on recent developments) will be successful. Therefore, Drake will be able to operate at NH₃/NO stoichiometric ratios of approximately 1.0. Experience at existing kilns shows that holding the ammonia slip at approximately 15 mg/Nm³ or 10–12 ppm is reasonable.

8.6.2.8 Suwannee American Cement (SAC) – Branford, Florida (Using SNCR)²

Several cement kilns in Florida have installed SNCR technologies, tested SNCR, or plan to install SNCR. All Florida cement kilns have multi-channel main kiln burners with indirect firing (meaning low primary air blowing in the pulverized coal) known as LNB, as well as MSC calciners.

SAC in Branford, FL (Figure 8-6) has an indirect-fired PH/PC kiln that began operation in 2003. The operators wanted to expand capacity and gain operational flexibility for controlling NO_x emissions. The original clinker production limit was 105 t/hr, and the requested limit was 120 t/hr. The SAC plant tested an SNCR system in November 2004 and permanently installed the system in April 2005.

The plant's calciner operates at about 1,090 °C (2,000 °F), and the rotary kiln operates at 1,650 °C (3,000 F). Both units burn coal. The preheater exhaust gases go through the raw mill and then to a baghouse. Fly ash is injected directly to the calciner and also to the top of preheater.



Figure 8-6. Suwannee American Cement – Branford, Florida.

According to plant personnel, the advantages of using SNCR are the following:³⁶

- Greater kiln stability
- Prolonged periods of increased production
- Fewer kiln process problems (build-up in riser duct)
- Reduced NO_x
- Possibility to use petroleum coke with current NO_x limits.

The disadvantages of using SNCR are the following:

- Higher than average CO
- Ammonia emissions observed during raw mill offline periods. Ammonia emissions may occur over longer periods of time when the raw mill system is operational.

In selecting where to inject the ammonia solution, it is important to separate the NO reduction reaction from combustion. This is ensured when the ammonia solution injection is done as close as possible to the bottom-stage cyclone. The actual injection location where ammonia was injected at the SAC plant is shown in detail in Figures 8-7 and 8-8 (Figure 8-7 also shows one of the four injection ports). The injection nozzle is shown in Figure 8-9.³⁷



Figure 8-7. SNCR injection location – Suwannee American Cement, Branford, Florida.

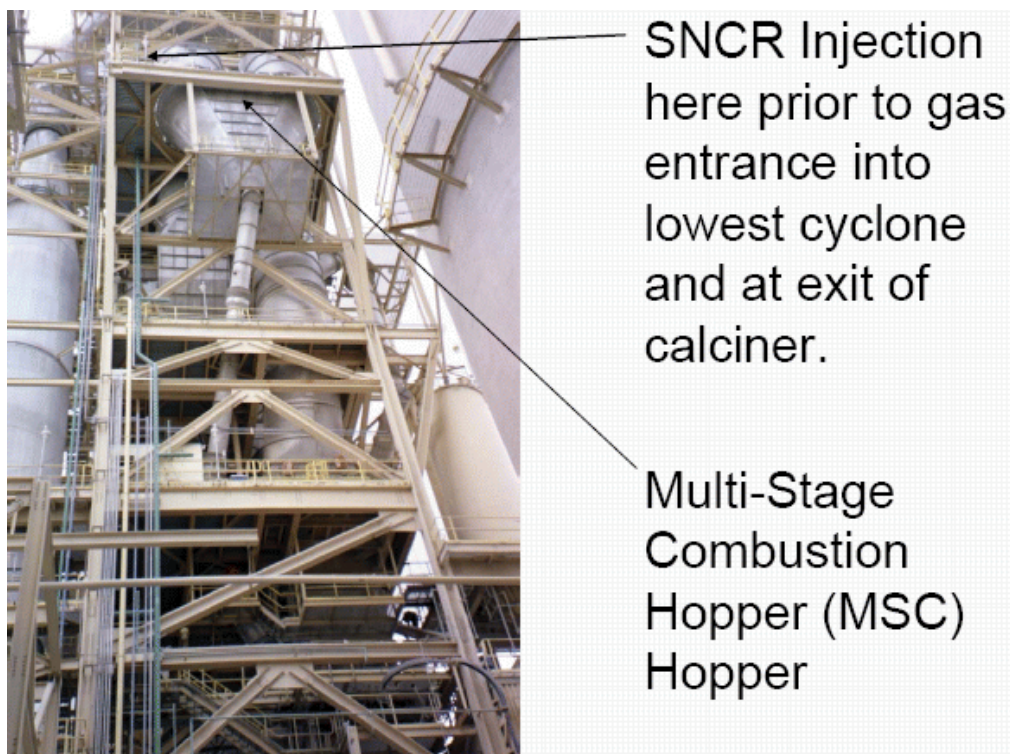

Figure 8-8. Ammonia injection, Suwannee American Cement.

The ammonia injection location was verified through previous testing in recent years by Polysius on kilns in Europe similar to the SAC PH/PC kiln. The location is in the later portion of

the calciner prior to the Stage 1 (lowest) cyclone and just beyond the MSC deflection chamber. This location has been demonstrated as the best location for Polysius MSC and MSC-combustion chamber kilns. Temperatures at this location were verified prior to testing and ranged from 870–910 °C (1,600–1,675 °F), with oxygen around 2%. This location provided optimal residence time at the needed temperature and oxidizing atmosphere, as well as the necessary turbulence for mixing the ammonia solution.³⁸



Figure 8-9. Suwannee American Cement ammonia injection nozzle.

At the injection location, gas temperatures averaged 860 °C (1,580 °F), which is at the low end of the temperature range for SNCR. When temperatures are at the lower end of range, CO emissions are minimal. When temperatures are in the higher end of range, reactivity of NH_2 improves, but CO emissions after the injection are much higher. In addition, if ammonia is injected in too high temperature gases, NO molecules may form instead of N_2 .³⁷

Full-scale SNCR tests were conducted on the existing kiln. There was no problem reaching 2.0 lb/t of clinker (29–33% control efficiency) while operating at 3.0–3.5 lb/t of clinker at kiln exit. The SNCR, in conjunction with MSC and separately from MSC was also tested, and both worked fine.

For two days prior to ammonia injection, normal NO_x emissions while utilizing MSC in conjunction with LNB resulted in NO_x emissions of 2.4–2.5 lb/t of clinker. SAC utilizes the MSC and the combustion chamber to create reducing conditions and frequently encounters process problems caused by this type of operation, such as strong reducing conditions and high CO at kiln inlet. Most typically, the problems consist of solids build-up in riser duct (lowest portion of the calciner prior to the entrance of the kiln). While establishing the baseline, SAC experienced some operational problems, as indicated by abrupt changes in clinker production, which signify process upsets or problems; however, overall operations were satisfactory.³⁸

Based on testing, the following conclusions were reached:

- NO_x emissions of 2.0 lb/t of clinker or below were achieved with SNCR with and without MSC. Increased process stability was realized during both testing periods, which led to increased production. The plant achieved high ammonia-utilization rates that were close to stoichiometric reductions.
- SNCR will promote stable kiln operation with the use of various approved fuels and will allow an increase in the production rate. When operating the kiln with higher exit oxygen levels, increased thermal NO_x is generated in the kiln, and NO_x stack emissions typically increase. The excess NO_x generated in the kiln is reduced by the reaction with ammonia. Flue gases coming out of the kiln are higher in NO_x (3-3.5lb/t) than coming out of the SNCR (2 lb/t).³⁹

Since the November 2004 testing and the permanent installation of the SNCR system, the SAC plant is achieving 2.4 lb/t (30-day average) and 2.9 lb/t (24-hr average). In addition, SO₂ and VOC emissions are low. The plant has determined that the SNCR system and moderate MSC is the least-expensive way to achieve these reduced emission levels. The plant will not use the already installed MSC in the calciner because the SNCR system is so efficient and process-friendly for their installation. The SNCR system has increased the plant's production capacity. The plant is meeting the 2.4 lb/t limit while injecting only half the theoretical amount of ammonia needed to neutralize NO_x.^{39, 40, 41}

Ammonia slip during periods when the raw mill is offline presents the possibility of detached plume problems because the raw mill operates as a scrubbing device for SO₂; therefore, offline periods could lead to both SO₂ and ammonia emissions.^{12, 37}

SAC has recently submitted an application for a new kiln system, one very similar in design to the existing PH/PC kiln system.^{2, 38, 39, 40, 42} The new kiln will have a capacity of 215 t/hr of material feed to the preheater and 127 t/hr of clinker production. The annual dry preheater feed will be limited to 1.789 million tons during any consecutive 12-month period and 1.055 million t/yr of clinker during any 12 consecutive months. Raw materials and additives for the new kiln are the same as the existing kiln system and include limestone, fly ash or other alumina sources, sand or other silica sources, and iron or other iron sources. Up to 45 t/hr of fly ash may be injected into the calciner.

For NO_x control, the SAC plant proposes to use indirect firing, low NO_x burners, staged combustion, and SNCR. The project is subject to PSD preconstruction review for CO, NO_x, PM/PM₁₀, SO₂, and VOC. A summary of the proposed BACT standards for this kiln is shown in Table 8-4.

Table 8-4. BACT Determinations – Suwannee American Cement, Branford, Florida, 11/05⁴²

Pollutant	Emission Standards (lb/t)	Emission Standards (lb/hr)	Averaging Time
CO	2.90	368	30-day rolling average – CEMS
NO _x	1.95	248	Same as above
NO _x (initial startup)	3.0	381	Same as above
PM/PM ₁₀	0.10 (of dry preheater feed material)	21.5	Average of 3 - 1hr test runs
	10% opacity		6-minute average w/ COMS
SO ₂	0.20	25.4	24-hr rolling CEMS average
VOC	0.12	15.2	30-day block CEMS average

8.6.2.9 Florida Rock Industries (FRI) – Newberry, Florida (SNCR Installed for Testing)

The FRI plant in Newberry, FL installed SNCR for testing purposes; however, SNCR is not being presently used because the kiln can achieve low NO_x levels with MSC. This modern PH/PC kiln was designed by Polysius and is shown in Figure 7-4. The FRI plant has a permitted clinker production rate of 2,650 t/day (110 t/hr), and both the kiln and the calciner are fired with coal. The kiln uses air and fuel staging on a Polysius MSC ILC. The calcination burner is mounted horizontally rather than in a separate combustion chamber, and provisions are included for a small burner in the kiln inlet housing. Instead of using a burner at the kiln inlet, FRI burns tires. Full-scale SNCR tests were conducted on the SNCR system on this existing kiln. The kiln had no problem reaching 2.0 lb/t. The December 2004 testing is described in detail in the sections below.¹² Tables 8-5 and 8-6 summarize the emission test results.

Table 8-5. Emission Test Results with Tires – Florida Rock Industries, Newberry, Florida, 12/04¹²

Uncontrolled NO _x (lb/t)	Controlled NO _x (lb/t)	Molar Ratio (NH ₃ /NO _x)	NO _x Reduction (%)
3.1	2.1	0.12	34
2.9	1.8	0.19	39
3.2	2.1	0.25	35
3.3	1.5	0.51	54
3.3	1.1	0.64	68
3.2	2.0	0.34	39

Table 8-6. Emission Test Results without Tires – Florida Rock Industries, Newberry, Florida, 12/04¹²

Uncontrolled NO _x (lb/t)	Controlled NO _x (lb/t)	Molar Ratio(NH ₃ /NO _x)	NO _x Reduction (%)
4.5	4.2	0.09	7
4.2	3.5	0.21	18
3.7	2.6	0.35	29
3.6	1.9	0.47	47
3.6	0.9	0.80	76
3.2	0.6	1.04	82

At lower molar ratios (< 0.5), NO_x efficiency was greater when tires were burned as fuel compared to the efficiencies when tires were not burned. At molar ratios of ~0.5, 50% control was achieved with or without burning tires. These data also show that NO_x is reduced by approximately 0.8 lb-moles with the injection of 1.0 lb-mole of ammonia (ammonia utilization rate of 80%) without burning tires.

FRI plans to install a new PH/PC kiln in a couple of years.⁴³ The new kiln will be a Polysius MSC system and will use an SNCR system in conjunction with MSC. The issued permit information shows that the new kiln will have a capacity of 206 t/hr of material feed, dry basis, to the preheater; 125 t/hr of clinker production; and 138 t/hr of Portland cement production.

The NO_x emission limit will be 1.95 lb/t (243.8 lb/hr) on a 30-day rolling average. For the first 180 operating days, the kiln cannot exceed 2.4 lb/t (30-days rolling average). As the project was subject to PSD review and BACT determinations for NO_x, PM, PM₁₀, SO₂, CO, and VOC, the other limits are the following:

- PM - 0.23 lb/t
- PM₁₀- 0.20 lb/t
- SO₂ - 0.23 lb/t
- CO - 3.6 lb/t
- VOC - 0.12 lb/t
- Hg - 122 lb/yr

8.6.2.10 Rinker/Florida Crushed Stone, Brooksville, Florida (SNCR Proposed)⁴⁴

This facility is planning a new line that is expected to be completed by 2007. It will have a capacity of 206 t/hr of material feed, dry basis, to the preheater and 125 t/hr of clinker production.

The NO_x emission limit will be 1.95 lb/t (243.8 lb/hr) on a 30-day rolling average. The project was subject to PSD review and BACT determinations for NO_x, PM, PM₁₀, SO₂, CO, and VOC. These limits are the following:

- PM - 0.23 lb/t
- PM₁₀- 0.20 lb/t

- SO₂ - 0.23 lb/t
- CO - 3.6 lb/t
- VOC - 0.12 lb/t
- Hg - 122 lb/yr

The proposed NO_x control is an SNCR system with MSC. The SNCR will operate in conjunction with MSC (including reducing conditions at the calciner, as needed).

8.6.2.11 Sumter Cement Company – New Center Hill, Florida (SNCR Planned)⁴²

Sumter Cement is planning to construct a new PH/PC kiln system with a capacity of 353 t/hr as feed to the preheater, resulting in 208 t/hr of clinker production. The expected operating hours are 7,883 hrs/yr. Raw materials and additives to the kiln will include limestone, fly ash, sand, and steel slag. Fly ash can be injected through the calciner burner. There will also be an in-line raw mill that simultaneously dries raw materials using the exhaust gas from the kiln, calciner, and clinker cooler.

The calciner will be designed to accommodate the introduction of fly ash and non-hazardous waste through the calciner burner. The burner will contain a specific chamber or nozzle within the burner for the simultaneous introduction of coal, petroleum coke, fly ash, and non-hazardous wastes. Petroleum coke typically has a lower reactivity and requires the longest retention time in the calciner.

Tires, either whole or shredded, may be used and injected via an airlock/gate system into the material inlet of the kiln. The tires produce a localized reduction zone around the tire fuel, which assists in NO_x reduction. The proposed tire gasification system would produce a combustible gas that would be injected into the kiln inlet or calciner region.

The primary fuel-firing scenario has 55–60% of total heat input in the calciner and 40–45% in the kiln main burner. This ratio will remain fairly constant. When tires are used, they may account for up to 15% of the heat input to the calciner. When using tire gasification, up to 40% of the calciner fuel may be supplied from tires.

The primary fuel for kiln and calciner burners will be ground bituminous coal and petroleum coke. Burners will be designed to burn non-hazardous liquids (e.g., fuel oil), which could produce up to 50% of total heat input in each burner. Solid nonhazardous waste may be used in the calciner burner and produce up to 50% of the total heat input.

To control NO_x, the plant will use a form of MSC (i.e., reducing zone), LNBS in the kiln, and SNCR. The Florida DEP determined that 1.95 lb/t (30-day rolling average) is the BACT level for this project.

8.6.2.12 American Cement Company – Sumterville, Florida (SNCR Planned)⁴⁵

Proposed BACT determined by the Florida DEP for this planned PH/PC kiln system is 1.95 lb/t (30-day rolling average). NO_x controls will be SNCR, LNBS in the kiln, kiln design, and MSC. MSC will be used to function with either fuel staging or combustion air staging and will

have flexibility in meal splitting. Kiln design refers to the PH/PC kiln system. The plant is designed for a clinker production of 1,150,000 t/yr.

Coal and petroleum coke will be burned in both the kiln and the calciner. The ratio of coal to petroleum coke burned will depend on process conditions, such as the material build-up, feed alkali content, and heating value of the fuel. Petroleum coke will not exceed 25–30% of petroleum coke/coal fuel mix.

Field tests by Polysius, demonstrated that a 65–70% NO_x reduction was achieved using a 25% ammonia water solution at a molar ratio of 1. In comparison, a 68% urea solution achieved only a 35–40% reduction at the same molar ratio. At a higher molar ratio than 1, ammonia slip becomes a problem.⁴⁶

8.6.2.13 Dragon Products Company – Thomaston, Maine (Installing SNCR)^{47, 48, 49}

NO_x emissions from Dragon's Thomaston, Maine facility were closely approaching their permit limit. To avoid exceeding their limit, the company decided to install an SNCR system on their dry kiln. The SNCR and kiln system are currently in a testing program and should be in operation in 2007. Pilot tests of the SNCR performed in November 2006 showed ammonia slippage of 10.3 ppm at 7% O₂ (3.24 lb NH₃/hr) with the raw mill on and 22.5 ppm at 7% O₂ (6.9 lb NH₃/hr) with the raw mill off. NO_x CEM data was not available for the period when these tests were being conducted. The part 70 air emission permit for Dragon is available at <http://www.maine.gov/dep/air/licensing/TitleVlicenses/a326ai.pdf>.

8.6.3 SNCR – Foreign Experience – Europe, Japan, Taiwan

8.6.3.1 Europe

SNCR has been applied to more than 30 German kilns, including rotary kilns with a cyclone preheater and rotary kilns with a grate preheater, as well as kilns with SCC. In addition, SNCR is increasingly being applied at cement plants in other European countries.

A stoichiometric ratio of > 1 is usually required to achieve high reduction rates. The target value is often a NO_x concentration as low as 200 mg/m³ (~1 lb/t). Ammonia slip may occur and can increase when there is not combined drying and grinding. Otherwise, a considerable amount of ammonia is deposited in the raw meal. Experience in numerous kilns indicates that this ammonia deposition is not detrimental to product quality. A 25% ammonia aqueous solution is still considered the standard reducing agent. In many cases, wastewater is used as a reducing agent.

The European experience with SNCR and cement kilns is more extensive than in the United States. Most European kilns with SNCR are the preheater kiln type, though there are a few PH/PC kilns. According to one source, SNCR is installed at 25 German kiln systems of different designs. Another reference states that there are presently 19 European cement plants with SNCR. Seventeen of these plants are preheater or traveling grate types. The two plants of PH/PC kiln type that use SNCR are located in Sweden.^{3, 50}

New kilns in Europe have to comply with an emission limit of 500 mg/Nm³ (2.3–2.5 lb/t). For existing plants, the limit is 800 mg/Nm³ (3.7–4.0 lb/t). Government agencies and cement industry organizations have collaborated in jointly funded studies to evaluate controls such as MSC, SNCR, and SCR.⁵¹

A European report indicated that SNCR on cement can achieve below 200 mg/m³ (80–85% control) if the initial NO_x concentration is not higher than 1,000–1,300 mg/m³. At one 2000 mt/day (2,200 t/day) plant, a molar ratio of 1.0 produced reductions of 80% without any increase in ammonia. Most SNCR applications are designed and or operated at NO_x reductions of 10–50%, with NH₃/NO₂ ratios of 0.5–0.9. The controlled emission levels are 500–800 mg NO_x /m³. NO_x reductions up to 90% may be achieved at NSR of 0.7–0.8 and ammonia slip equal to 5 mg/m³. Based on experience in Europe, an ammonia solution is the best agent for PH/PC kilns.^{3, 50}

The findings on SNCR use in Europe from one report are summarized as follows:⁵²

- NO_x abatement of 50 –70% is achievable and is used in more than 60 cement works, some on a trial basis
- Target values of 800 mg/m³ are readily attainable; in most cases 500 mg/m³ can be achieved.
- Lower values – 200 mg/m³ have already been achieved – often with high ammonia slip
- Specific costs (capital and operating) for SNCR– 0.5-0.7 euro/t.
- Best Available Technologies (BAT) reference document designates an achievable NO_x emission limit of 200 –500 mg/m³.
- 200 mg/m³ was achieved with SNCR on one PH/PC kiln with little ammonia slip. A wet scrubber lowers SO₂ emissions and retains unreacted ammonia.
- Before SNCR – NO_x levels of 1,000 mg/m³ lower than a few yrs ago. SNCR control target – 400–500 mg/m³.
- NO_x level of 800 can be achieved even with high starting level. Molar ratio often < 1 with low ammonia slip.
- 500mg/m³ can be achieved in almost all cases. Molar ratio > 1; slight increase in ammonia slip.
- 200 mg/m³ can be achieved with low starting point. Molar ratio > 2 – high ammonia slip.
- Possible increase in CO emissions with SNCR.
- SNCR with SCC – an emerging technology. Promising technology to achieve 100 – 200 mg/m³.

8.6.3.2 Japan/Taiwan¹

There are 10 cement plants in Japan and 1 in Taiwan that use SNCR. Detailed information was available on an existing Taiwan plant using urea with two coal-fired kilns each at 90 mt/hr (99 t/hr). The goal was to reduce NO_x below 500 ppm. A summary of the results is shown on Table 8-7.

Table 8-7. SNCR at a Taiwan Cement Plant

	Kiln A	Kiln B
NO _x baseline; ppm	389–412	525
Annual NO _x reduction (%)	> 50	46
Controlled NO _x ; ppm	185–203	284

8.7 SUMMARY OF SNCR PERFORMANCE

Table 8-8 summarizes the performance of PH/PC cement kilns (except the Cemex plant, which has a preheater kiln) that have installed SNCR systems. Most SNCR systems use an ammonia solution. It appears that an emission level of 2.0 lb/t of clinker is achieved with an NSR of 0.5. At a higher NSR ratio of 1.0, NO_x could be reduced to around 1.0 lb/t of clinker. Uncontrolled NO_x (after SCC, LNB in the kiln and process controls) is 2.7 lb/t of clinker (see Table 7-3). On average, SNCR achieves a 35% reduction at an NSR of 0.5 and a 63% reduction at an NSR of 1.0. Ammonia slip may be a problem as the NSR is increased.

Table 8-8. SNCR Summary

Plant/Source	Control Level (lb/t)	Efficiency (%)	NSR
3 European kilns ⁸	NA	25–50; 35–60; 42–72	0.6; 0.8; 1.0
Ash Grove, Seattle ¹³	2.2; 1.3	25; 55	0.5; 1.0
Hercules; PA ¹⁹	300 ppm ~3.0	12–25	NA
Cemex; FL-preheater kiln ²⁴	2.0	50	0.6–0.7
Suwannee American ³⁷	2.0	33–50	NA
Florida Rock ¹² without tires	1.9; 2.6	47; 29	0.47; 0.35
Florida Rock ¹² with tires	2.1	34	0.12–0.25
Holcim – Texas ³⁰ (2 kilns)	NA	47, 32	0.7
European Report ⁵¹ -achievable	1.0	80–85	NA
European Report ⁵¹ - actual operation	2.5–4.0	10–50	0.5–0.9
Skovde, Sweden ^{3,50}	0.5–1.0	80–85	1.0–1.1
Slite, Sweden ^{3,50}	1.1	80	1.0
Taiwan-2 kilns ¹	194 ppm; 284 ppm ~2.0; 2.9	50; 46	NA

8.8 REFERENCES

1. Environment Canada. *Foundation Report of the Cement Manufacturing Sector*. Draft #1. Prepared by Minerals and Metals Branch, Pollution Prevention Directorate. June 18, 2004.
2. Florida Department of Environmental Protection. *Technical Evaluation and Preliminary Determination – Suwannee American Cement, Branford, FL*. Permit Modification to Increase Production, Inject Fly Ash into Calciner, Install a Selective Non-Catalytic

- Reduction System. DEP File No. 1210465-011-AC. Division of Air Resources Management. February 16, 2005.
3. VDZ (German Cement Works Association). Environmental protection in cement manufacture. Chapter II in *VDZ Activity Report 2003 –2005*. Figure II-15, p. 55. 2005.
 4. Email transmission from A. Linero, Florida Department of Environmental Protection, to B. Neuffer, U.S. Environmental Protection Agency. *SNCR at Hercules Cement – Stockertown, PA*. January 30, 2005.
 5. Mussatti, D.C., R. Srivastava, P.M. Hemmer, and R. Strait. “Figure 1.3: Effect of Temperature on NO_x Reduction” from Chapter 1 – Selective Noncatalytic Reduction. In *EPA Control Manual, Section 4 – NO_x Controls, Section 4.2 – NO_x Post-Combustion*. EPA/452/B-02-001. Prepared for U.S. Environmental Protection Agency. October 2000. Available at www.epa.gov/ttn/catc/dir1/cs4-2ch1.pdf.
 6. Portland Cement Association. *Report on NO_x Formation and Variability in Portland Cement Kiln Systems Potential Control Techniques and Their Feasibility and Cost Effectiveness*. PCA R&D Serial No. 2227. Prepared by Penta Engineering Corp. 1999.
 7. U.S. Environmental Protection Agency. *NO_x Control Technologies for the Cement Industry*. Prepared by EC/R Incorporated. September 19, 2000. Available at www.epa.gov/ttn/naaqs/ozone/ozonetech/cement_nox_update_09152000.pdf.
 8. Schafer, S. *Staged Combustion and SNCR Technology – an Emerging Technique?* Research Institute of the Cement Industry (Duesseldorf). Seminar S04-05. Bernburg. European Cement Research Academy. November 3–4, 2004.
 9. Mussatti, D.C., R. Srivastava, P.M. Hemmer, and R. Strait. “Section 1.2.3 SNCR Performance Parameters” from Chapter 1 – Selective Noncatalytic Reduction. In *EPA Control Manual, Section 4 – NO_x Controls, Section 4.2 – NO_x Post-Combustion*. EPA/452/B-02-001. Prepared for U.S. Environmental Protection Agency. October 2000. Available at www.epa.gov/ttn/catc/dir1/cs4-2ch1.pdf.
 10. Hower, J. *Cement Kiln Application of Selective Non-Catalytic Reduction – Myth or Reality?* Presented at IEEE Florida Meeting, May 2002
 11. Mussatti, D.C., R. Srivastava, P.M. Hemmer, and R. Strait. “Figure 1.5: Effect of Uncontrolled NO_x Level on NO_x Reduction Efficiency” from Chapter 1 – Selective Noncatalytic Reduction. In *EPA Control Manual, Section 4 – NO_x Controls, Section 4.2 – NO_x Post-Combustion*. EPA/452/B-02-001. Prepared for U.S. Environmental Protection Agency. October 2000. Available at www.epa.gov/ttn/catc/dir1/cs4-2ch1.pdf.
 12. Linero, A. *SNCR NO_x at US Cement Plants. Is SCR Close Behind?* Paper #638 presented at the AWMA Annual Conference. June 2005.
 13. Steuch, H.E., J. Hille, W.H. Sun, M.J. Bisnett, and D.W. Kirk. “Reduction of NO_x Emissions from a Dry Process Preheater Kiln with Calciner Through the Use of the Urea

DRAFT – DO NOT QUOTE OR CITE

Based SNCR Process.” *IEEE Transactions on Industry Applications*, Vol. 32, Issue 4, July/August 1996. Pp. 753–759.

14. U.S. Environmental Protection Agency. *Alternative Control Techniques Document – NO_x Emissions from Cement Manufacturing*. EPA-453/R-94-004. March 1994. Available at www.epa.gov/ttn/cata/dir1/cement.pdf.
15. Letter from H. Knopf, Process and Environmental Manager, Lafarge Cement, Davenport, IA, to C.A. Roling, Environmental Engineer, Iowa Department of Natural Resources. *Project #96-494 (SNCR Technology)*. May 14, 1998.
16. Lehigh Portland Cement Company. *Selective Non-Catalytic NO_x Reduction Demonstration (SNCR)*. Mason City, Iowa, Plant. December 22, 2000.
17. Lanier, W.S. *Public Comment to Proposed PSD Permit for Lafarge Davenport Cement Manufacturing Facility*. Energy and Environmental Research Corporation. Undated
18. Williams, K.E. *Hercules Cement Company & the Use of Ammonium Hydroxide Solution to lower NO_x Emissions at its Stockertown, PA Plant*. Presented at the AWMA Annual Meeting, San Diego, CA. June 22–26, 2003.
19. Email transmission from W. Nuver, Air Quality Program, Pennsylvania Department of Environmental Protection, to B. Neuffer, U.S. Environmental Protection Agency. *Hercules Cement SNCR*. March 9, 2005.
20. Email transmission from A. Linero, Florida Department of Environmental Protection, to B. Neuffer, U.S. Environmental Protection Agency. *SNCR at Hercules Cement – Stockertown, PA*. January 30, 2005.
21. Email transmission from D. Thorley, Michigan Department of Environmental Protection, to B. Neuffer, U.S. Environmental Protection Agency. *SNCR system at St Mary’s Cement – Charlevoix, Michigan*. June 2, 2005.
22. Email transmission from D. Thorley, Michigan Department of Environmental Protection, to B. Neuffer, U.S. Environmental Protection Agency. *Charlevoix 2005 NO_x numbers MDEQ.xls*. October 25, 2005.
23. Teleconference. C. Dennison, St Mary’s Cement, with B. Neuffer, U.S. Environmental Protection Agency. *SNCR Test Trails – St Marys Cement*. October 25, 2005.
24. Email transmission from A. Linero, Florida Department of Environmental Protection, to B. Neuffer, U.S. Environmental Protection Agency. *SNCR on Preheater Kiln*. October 26, 2005.
25. Email transmission from I. Uphoff, Downwinders at Risk, Dallas, TX, to B. Neuffer, U.S. Environmental Protection Agency. *Summary of 11/30/05 call*. December 1, 2005.

DRAFT – DO NOT QUOTE OR CITE

26. Email transmission from I. Uphoff, Downwinders at Risk, Dallas, TX, to B. Neuffer, U.S. Environmental Protection Agency. *Holcim – Midlothian*. December 7, 2005.
27. Email transmission from I. Uphoff, Downwinders at Risk, Dallas, TX, to B. Neuffer, U.S. Environmental Protection Agency. *Holcim – Midlothian*. December 8, 2005.
28. Letter from M. Moser, Plant Manager, Holcim, Midlothian, TX, to R. Hamilton, Texas Commission on Environmental Quality. *Holcim (Texas) LP – Submittal of Selective Non-Catalytic Reduction (SNCR) Pilot Test Summary Report*. November 29, 2005.
29. Letter from A. Armendariz to M. Moser, Plant Manager, Holcim, Midlothian, TX. December 28, 2005.
30. Holcim. *SNCR Pilot Test Report*. Midlothian Plant. November 2005.
31. Teleconference. M. Moser, Holcim, with B. Neuffer, U.S. Environmental Protection Agency. May 31, 2006.
32. Missouri Department of Natural Resources. *Project Review of Application for Permit to Construct According to 10 CSR 10-6.060 Section (8)*. Holcim US – Lee Island Project, Bloomsdale, MO. Undated.
33. Missouri Department of Natural Resources. *Permit to Construct, Permit Number 062004-005*. Holcim – Lee Island Project, Bloomsdale, MO. June 8, 2004.
34. Email transmission from C. Roling; Iowa Department of Natural Resources, to B. Neuffer, U.S. Environmental Protection Agency. *Summary of telecom on Lehigh PC – Mason City, IA*. January 26, 2005.
35. Arizona Department of Environmental Quality. *Class I Prevention of Significant Deterioration Operating Permit Application – ADEQ Permit No. 1001770*. Drake Cement, L.L.C., Phoenix, AZ. January 4, 2005.
36. Letter from R.R. Patron, Drake Cement, Phoenix, AZ, to E. Massey; Air Quality Permits Section, Arizona Department of Environmental Quality. *Air Quality Permit Application No. 1001770 – Five Technical Issues*. February 25, 2005.
37. Polysius Corporation. *Selective Non Catalytic Reduction Test Report*. Suwannee American Cement, Branford, FL. November 2004.
38. Letter from J. Horton, Suwannee American Cement, to T. Vielhauer, Florida Department of Environmental Protection. *Selective Non-Catalytic Reduction (SNCR) Test Report*. February 10, 2005.
39. Email transmission from A. Linero, Florida Department of Environmental Protection, to B. Neuffer, U.S. Environmental Protection Agency. *SNCR Start ups in Suwannee*. March 23, 2005.

40. Email transmission from A. Linero, Florida Department of Environmental Protection, to B. Neuffer, U.S. Environmental Protection Agency. *More cement news from Florida*. May 23, 2005.
41. Letter from M.G. Cooke, Director, Division of Air Resource Management, Florida Department of Environmental Protection, to T. Messer, Plant Manager, Suwannee American Cement, Branford, FL. *Production Increase, Fly Ash Injection, SNCR*. March 7, 2005.
42. Florida Department of Environmental Protection. *Technical Evaluation & Preliminary Determination*. Suwannee American Cement. Proposed Kiln Line No. 2, Branford, FL. November 8, 2005.
43. Email transmission from A. Linero, Florida Department of Environmental Protection, to B. Neuffer, U.S. Environmental Protection Agency. *Latest Cement News*. Available at www.dep.state.fl.us/Air/permitting/construction/flock.htm. March 30, 2005.
44. Florida Department of Environmental Protection. *Best Available Control Technology Determination (BACT) – Florida Crushed Stone, Brooksville, FL*. Available at www.dep.state.fl.us/Air/permitting/construction.htm. Accessed March 6, 2007.
45. Florida Department of Environmental Protection. *Technical Evaluation, Preliminary Determination, Draft BACT Determinations – American Cement Company, Sumterville, FL*. December 16, 2005. Available at www.dep.state.fl.us/Air/permitting/construction/americanTEPD361.pdf.
46. Terry, M.S. *From BACT: What is Achievable with Today's Technologies?* Polysius Corporation. Undated
47. Email transmission from M. Roberts, Maine Department of Environmental Protection, to B. Neuffer, U.S. Environmental Protection Agency. *Dragon Cement – Thomaston, ME*. March 9, 2007.
48. Email transmission from M. Roberts, Maine Department of Environmental Protection, to B. Neuffer, U.S. Environmental Protection Agency. *Dragon Cement – Thomaston, ME*. March 13, 2007.
49. Email transmission from B. Neuffer, U.S. Environmental Protection Agency, to M. Roberts, Maine Department of Environmental Protection. *Dragon Cement – Thomaston, ME*. March 9, 2007.
50. VDZ (German Cement Works Association). Environmental protection in cement manufacture. Chapter II in *VDZ Activity Report 2003 –2005*. Figure II-15, p. 55. 2005.
51. Swedish Environmental Protection Agency. *Reduction of nitrogen oxides with SNCR technology at Slite cement plant*. Per Junker, Director of Environment Protection. Session 16 Cement Industry.

52. Scur, P., and H. Hoppe. *The present state of NO_x abatement with the SNCR process*. Cement International. February 2006.

9.0 MULTISTAGE COMBUSTION (MSC) AND SELECTIVE NONCATALYTIC REDUCTION (SNCR)

Most if not all new PH/PC kiln systems will have some form of MSC. This section summarizes studies on the effect of the combination of MSC and SNCR. In an MSC calciner, part of the calciner fuel is introduced at the kiln inlet to reduce the NO generated in the kiln. The adjustable division of the tertiary air allows part of the calciner to be operated under sub-stoichiometric conditions. This leads to the reduction of NO formation from the fuel nitrogen and, depending on the type of calciner fuel used, the reduction of more of the NO produced in the kiln.

One European report¹ states that considerable CO is formed in staged combustion, but that most of the CO is burned out in the area of the mixing chamber and the bottom cyclone stage. Operation of an SNCR system substantially impairs CO burn-out. During SNCR trials, CO rose from 0.02 to 0.05%.²

Causes for the interaction between the SNCR and CO burn-out rate have not been identified. SNCR and CO decomposition both require OH radicals. It may be preferable to create separate reaction zones for SNCR and MSC. If SNCR is installed in an existing calciner kiln, this can be implemented by injecting the reducing agent at a point where co-burning has progressed sufficiently. The design of new calciners should allow for sufficient gas residence time to allow CO burnout and SNCR reactions to take place consecutively.

A European study was undertaken to study the combination of SNCR and staged combustion as an “emerging technique.” It was assumed that this combination could attain NO_x emissions of 100–200 mg/m³.²

The report states that there are competitive reactions of MSC and SNCR. These reactions are listed below.

NO_x reduction

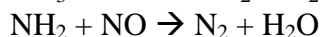
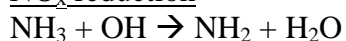

CO oxidation

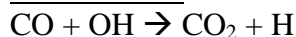

Four different kilns were tested to evaluate the effects of SNCR on PH/PC kilns with staged combustion; the results of these tests are summarized below. As shown in Table 9-1, NO_x reductions attributable to only SNCR varied from 45–65%. CO emissions increased when the NSR was at least 1.2, and the NO_x reduction due to SNCR was at least 50%.

Table 9-1. Effect of SNCR on Emissions with Staged Combustion²

Kiln	B	B	D	M	X	X
NSR	0.6	0.9	1.2	1.5	2.5	2.7
NO _x reduction due to SNCR (percent)	47	45	50	65	65	65
CO increase (ng/ m ³)	0	0	125	375	290	950

Figure 9-1 illustrates the effects on NO levels resulting from the injection of ammonia in the burnout zone. As NSR increases (more NH₃ injected), the level of NO_x emitted decreases. These effects are also summarized in Table 9-2.

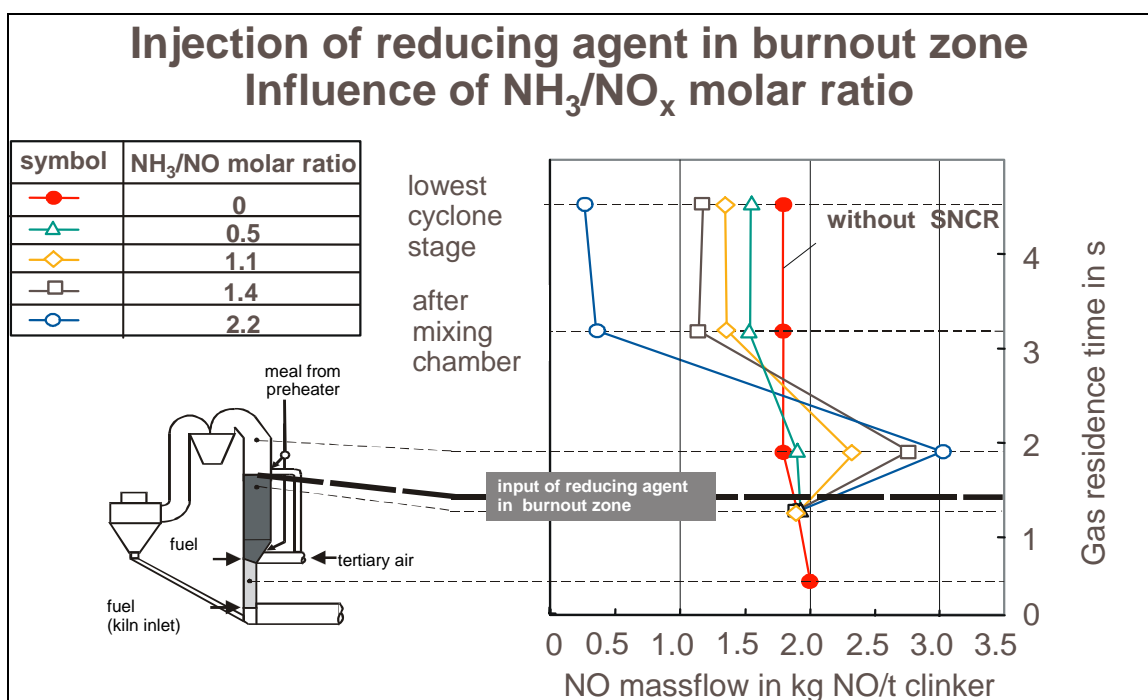

Figure 9-1. NH₃ injection – burnout zone.²

Table 9-2. Impact of Injecting Ammonia in Burnout Zone²

NSR	NO After Mixing Chamber (kg/mt)	NO in Lowest Cyclone Stage NO(kg/mt)
0	1.8	1.8
0.5	1.6	1.6
1.1	1.3	1.3
1.4	1.1	1.1
2.2	0.4	0.3

The impacts of injecting ammonia in the reducing zone are illustrated in Figure 9-2 and summarized in Table 9-3. These show that the level of NO_x emissions consistently decreases with increasing NSR.

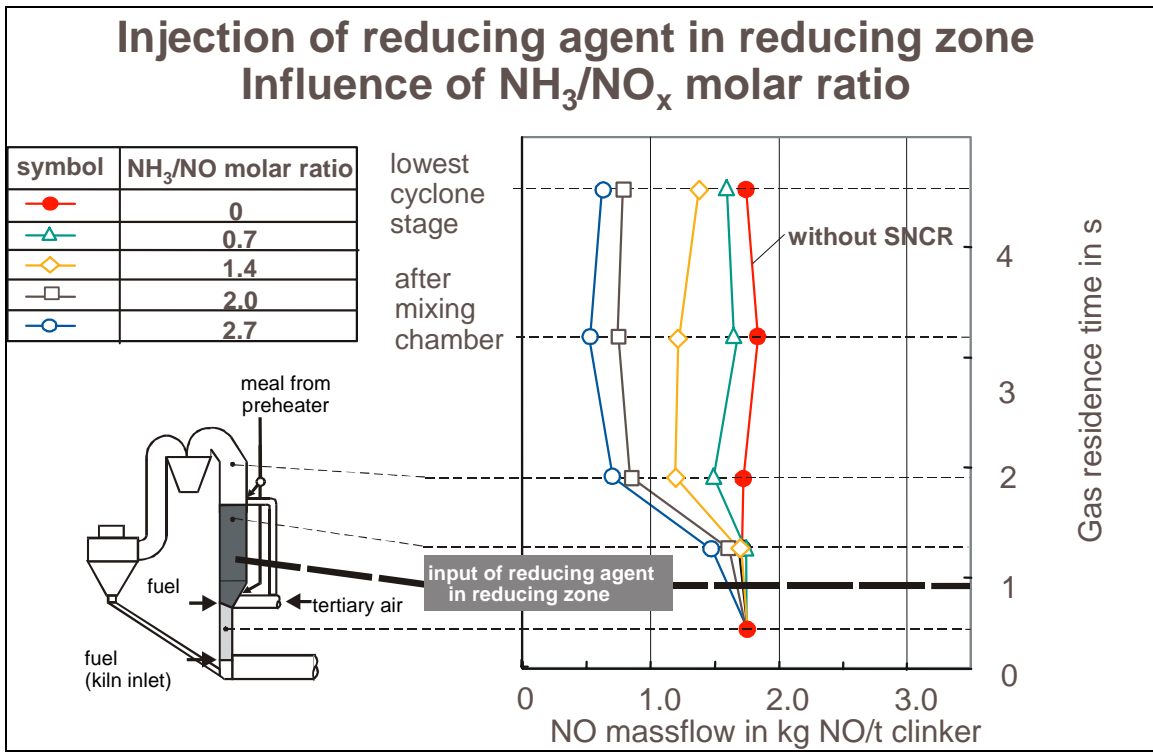

Figure 9-2. NH₃ injection – reducing zone.²

Table 9-3. Impact of Injecting Ammonia in Reducing Zone²

NSR	NO After Mixing Chamber (kg/mt)	NO in Lowest Cyclone Stage (kg/mt)
0	1.8	1.7
0.7	1.6	1.6
1.4	1.2	1.5
2.0	0.8	0.8
2.7	0.6	0.7

The following conclusions regarding the combination MSC and SNCR have been reported:²

- MSC combined with SNCR is feasible
- CO burnout and SNCR processes affect each other
- CO can increase
- The optimum point for feeding the reducing agent should be determined for each plant.

The same report² had the following conclusions on the interaction of SC with SNCR:

- The higher the ammonia input into the combustion chamber, the more retarded the CO burnout
- CO can increase if the residence time is too short after injection
- The calciner design must provide 1–1.5 seconds residence time for SNCR
- The input of the reducing agent can be limited by the potential for CO increase. CO increase can be avoided by increasing the air ratio in the reduction zone (less air staging).

The report stated that the solution to increased CO levels is to improve burnout by increasing the air ratio in the reduction zone (less air staging).

According to the Florida DEP, a cement kiln in Florida would operate very comfortably at around 3.6 to 4 lb/t of clinker in a PH/PC kiln with oxidizing conditions in the calciner.³ Efforts toward MSC and a high-temperature reducing atmosphere will result in costs due to increased coatings, pluggage, and the increased sizes of precalciner and preheater. An emission rate between 1 and 4 lb/t of clinker is BACT for the given kiln. There will be a least-cost combination of SCC and SNCR or just one or the other. According to the Florida DEP, BACT will be much closer to the lower end of the range of emissions.³

Krupps-Polysius conducted trials indicating that the combination of MSC with SNCR can achieve values of 800 mg for existing kilns and 500 mg/Nm³ for new kilns.⁴ The MSC calciner is characterized by kiln inlet burner, staggered tertiary air introduction, staggered meal introduction, and a deflection chamber located before the first cyclone. Best results for NO_x reduction were obtained by injecting an ammonia solution before and after the deflection chamber. The smallest plants show the best reduction rates. This is attributable to the difficulty of mixing a small amount of liquid into a large gas volume. A reduction occurs only above a molar ratio of 0.2; below this, it cannot be ruled out that part of the ammonia oxidizes and reduces the reduction effect to such an extent that it is practically zero.

A CO increase is also linked to the molar ratio. With molar ratios of less than 1, CO increases range between 150–350 mg/m³. Above molar ratios of 1, CO increases can reach 600–800 mg/m³, depending on the magnitude of the molar ratio. This CO increase is not a characteristic of the combined MSC/SNCR process, but is instead due to the SNCR process itself.

The use of MSC/SNCR controls becomes economically attractive at total reduction rates above 35–45%. MSC leads to a reduction in ammonia requirements for SNCR. SNCR allows kiln operation without direct coupling to emission limits, leaving the kiln operator more freedom of action.

9.1 REFERENCES

1. VDZ (German Cement Works Association). Environmental protection in cement manufacture. Chapter II in *VDZ Activity Report 2003–2005*. Figure II-15, p. 55. 2005.

2. Schafer, S. *Staged Combustion and SNCR Technology – an Emerging Technique?* Research Institute of the Cement Industry (Duesseldorf). Seminar S04-05. Bernburg. European Cement Research Academy. November 3–4, 2004.
3. Email transmission from A. Linero, Florida Department of Environmental Protection, to B. Neuffer, U.S. Environmental Protection Agency. *RE: Cement Kilns – SNCR*. January 6, 2005.
4. Erpelding, R. *NO_x Reduction with the MSC/SNCR combination: Chances and Risks*. Krupp Polysius AG. Undated.

10.0 SELECTIVE CATALYTIC REDUCTION (SCR)

There are presently two cement kilns in the world using that use selective catalytic reduction (SCR): Solnhofen in Germany and Cementeria di Monselice in Italy. Both kilns are preheater kilns. These plants will be discussed in detail later in this section.

10.1 PROCESS DESCRIPTION

SCR is the process of using ammonia or urea in the presence of a catalyst to selectively reduce NO_x emissions from exhaust gases. The SCR process has been used extensively on gas turbines, internal combustion (IC) engines, and fossil fuel-fired utility boilers. In the SCR system, anhydrous ammonia, usually diluted with air or steam or aqueous ammonia solution, is injected through a catalyst bed to reduce NO_x emissions. A number of catalyst materials have been used, such as titanium dioxide, vanadium pentoxide, and zeolite-based materials. The catalyst is typically supported on ceramic materials (e.g., alumina in a honeycomb monolith form) and promotes the NO_x reduction reactions by providing a site for these reactions to occur. The catalyst is not consumed in the process but allows the reactions to occur at a lower temperature.

The optimum temperature for the catalyst reactions depends on the specific catalyst used. Several different catalysts are available for use at different exhaust gas temperatures. Base metal catalysts are useful between 450 °F and 800 °F. For high temperature operations (675 °F to over 1100 °F), zeolite catalysts containing precious metals such as platinum and palladium are useful. The two principal reactions in the SCR process at cement plants using SCR are the following:

- $4 \text{NH}_3 + 4 \text{NO} + \text{O}_2 \rightarrow 4 \text{N}_2 + 6 \text{H}_2\text{O}$ (predominant reaction as most NO_x is NO)
- $4 \text{NH}_3 + 2 \text{NO}_2 + \text{O}_2 \rightarrow 3 \text{N}_2 + 6 \text{H}_2\text{O}$

In an SCR system, ammonia is typically injected to produce a NH₃: NO_x molar ratio of 1.05–1.1:1 to achieve a NO_x conversion of 80–90% with an ammonia slip of about 10 ppm of unreacted ammonia in gases leaving the reactor.³ The NO_x removal efficiency depends on the flue gas temperature, the molar ratio of ammonia to NO_x, and the flue gas residence time in the catalyst bed. All these factors must be considered in designing the desired NO_x reduction, the appropriate reagent ratios, the catalyst bed volume, and the operating conditions. As with SNCR, the appropriate temperature window must be maintained to assure that ammonia slip does not result in a visible plume.^{2,3}

SCR can be installed at a cement kiln at two possible locations:

- After the PM control device – a “low-dust” system.
- After the last cyclone without ducting – a “high-dust” system.

The advantages of a “low-dust” system are longer catalyst life and lower danger of blockage. The disadvantage is the additional energy costs required to heat the cooled exhaust to achieve proper reaction temperatures in the catalyst.

The advantage of a high-dust system is that the exhaust gas temperature after the cyclone is more or less equal to the temperature required by the catalyst. Additional heating is not required.² The two European cement kilns controlled by SCR are high-dust applications.

The catalysts may be fouled or deactivated by the PM in the flue gas, and soot blowers have been used to help alleviate this problem. Also, the presence of alkalis and CaO and SO₂ in exhaust gas is of concern. For coal-fired boilers, SCR is typically installed after PM control. In a cement kiln application where the SCR is placed after the PM control, flue gas reheating would be required because the temperature of the kiln exhaust after PM control is lower than typical SCR operating temperatures.

10.2 EQUIPMENT NEEDED FOR SCR⁴

The main component of SCR is the catalyst. The SCR catalyst composition and shape will vary depending on the application. Commonly, a carrier titanium oxide and active vanadium oxide components are supported on a ceramic substrate. Each catalyst module may be in a honeycomb or plate configuration and is typically arranged in a series of layers called beds. A support structure is required to house the catalyst beds and hold them in place. The enclosed chamber where the gases and ammonia react on the catalyst is called the SCR reactor.

Dust loading can lower the overall effectiveness of the catalyst. In a high-dust environment, the catalyst may actually become plugged. As a catalyst becomes plugged, the pressure drop across the catalyst increases; therefore, a catalyst-cleaning system must accompany the catalyst. Cleaning systems may include equipment such as dampers to reverse the gas flow, or additional devices such as sonic horns to vibrate dust loose. These systems may also use pressurized air nozzles or blowers to blow the dust from the catalyst. Pressurized air used to clean the catalyst must be preheated to maintain the temperature around the catalyst in the range that is optimal for the ammonia-NO_x reaction to take place, approximately 300–450 °C (570–840 °F) and to avoid localized acid gas dew point problems.

These cleaning techniques can be used while the SCR system operates. It is sometimes necessary to periodically remove each individual catalyst bed for more thorough cleaning using water or other solvent solutions. The system may include hoists, trolleys, or a crane to remove the catalyst beds. The wastewater and solids generated during this cleaning process must be properly managed and disposed.

As exhaust gases move past or through the catalyst, there will be an additional pressure drop. To move the gases, existing air-handling equipment, such as fans and blowers, may need to be scaled up. Eventually, a catalyst will reach the end of its useful life and need to be replaced with new catalyst elements. If not physically damaged, a catalyst can often be regenerated and used again. Figure 10-1 shows the tower structure that holds the catalyst, SCR reactor, and gas – moving and connection ductwork at the Solnhofen plant. As shown here, the SCR reactor and the associated ductwork is substantial in both size and required foundations for support.



Figure 10-1. SCR system adjacent to preheater tower at Solnhofen Portland cement plant.⁵

As with SNCR, SCR requires onsite vessels and a truck-unloading stand to receive and store ammonia or urea. Ammonia and urea may be received as a liquid solution or may be mixed onsite with water to the desired solution concentration. If mixed on site, additional water storage, purification, pumping, and mixing equipment is required.

The ammonia solution is pumped through metal pipes and delivered into the reaction chamber through a reaction lance. This will require a pump, pump skid, and ammonia control unit. The exact location and number of injection points will differ from one system to the next and is optimized through testing. Measurement equipment is necessary to maintain the correct feed rate of ammonia. Additional monitoring equipment is required to record the amount of NO_x and ammonia slip from the gases exiting the system to adjust the amount of ammonia entering the system.

Temperature and pressure readings from inside the SCR reactor are required for proper system adjustment and control. Finally, a bypass duct system is required in case the pressure drop through the SCR becomes too large, the temperatures become too high or too low for proper catalyst performance, or the SCR reactor needs to be taken offline for catalyst change-out.

10.3 EARLY PILOT TESTS

10.3.1 USA

In 1976, Hitachi Zosen, an SCR manufacturer, conducted three test programs on two suspension preheater kilns and a wet process kiln.¹ Each kiln was tested for 5,400 hours. ESPs were used to remove PM before the flue gas entered the SCR unit. Also, a heat-recovery system with supplemental fuel firing was used to raise the flue gas temperature to the required reaction temperature. Slipstreams of about 3,000 standard cubic feet per minute (scfm) were treated with initial NO_x removal efficiencies of 98%; however after about 5,400 hours of operation, NO_x removal efficiencies dropped to about 75% due to catalyst coating.¹ Based on these tests, the

ACT stated that SCR is a possible technology for cement kilns. The NO_x reductions were projected to be 80–90% regardless of kiln type.¹ Further developmental studies are needed to demonstrate the specific NO_x reduction.¹

10.3.2 Europe

ELEX is a Swiss engineering firm that has tested SCR at three different pilot units at three different cement plants for a total of 30,000 operating hours.⁶ The first pilot test was in Italy in 1996; however, information about this unit is not readily available. The second pilot test was conducted in Kirchdorf, Austria, using a slipstream of 3,500 m³/hr. The pilot plant was operated starting in 1996 for about 13,000 hours or about 2 years. NO_x was reduced continuously to 200 mg/Nm³ (one-half hour average). Ammonia slip was under 5 mg/Nm³.

Liquid ammonia was the reagent used, and the SCR unit had three catalyst layers. The catalyst was placed ahead of the PM control. The gas temperature was between 300–400 °C (570–750 °F) with a dust load of 80 g/m³. SO₂ concentrations were typically between 150–300 mg/Nm³.

Some inlet concentrations of 640 mg/Nm³ (~ 2.6 lb/t) were reduced to 100 mg/Nm³ (~0.4 lb/t) and below. Ammonia slip was considerably below 5 mg/Nm³. After 2,200 operating hours, the catalyst activity was 92%. The pilot was operated for 13,000 hours with low NO_x emissions, low ammonia slip, and no unexpected drop in catalyst activity.

The third pilot test was at Slite Cement in Sweden. Although the test was successful, the plant was able to achieve low NO_x emissions using SNCR, so a full-scale SCR system was not constructed.

10.4 SCR INSTALLATIONS

10.4.1 Solnhofen – Germany^{2, 4, 8, 9, 10}

As mentioned above, there are two known cement kilns in the world that use SCR. The first plant that installed SCR is Solnhofen in Germany. The Solnhofen cement kiln is a preheater kiln, not a PH/PC kiln system. As discussed earlier, uncontrolled NO_x emissions for preheater kilns are higher than PH/PC kilns. The Solnhofen plant produces 500,000 mt/yr (555,000 t/yr) of cement.

A pilot-scale demonstration was conducted in 1997–99 at Solnhofen. The SCR system was installed after the preheater in temperature between 300–340 °C (570–640 °F). The pilot demonstration showed the following:

- Catalyst pitch should be greater than 8 mm for easier cleaning
- NO_x was reduced by 30% with no ammonia usage other than the ammonia in the raw materials
- NO_x reduction rates above 90% were achieved with ammonia slip less than 5 ppm.

A commercial SCR was installed at Solnhofen in 2000 (see Figure 10-1). The SCR installation was a high-dust installation (i.e., the SCR reactor is located before the PM control

device) and uses a 25% aqueous ammonia solution. The system reduced raw material NH_3 that might have otherwise been converted to raw material NO_x . Also, ammonia slip was less than 1 mg/m^3 . Reductions of hydrocarbons and SO_2 in the order of 50–70% were also attained.

The reactor can be equipped with six catalyst layers, of which three layers are used. Using these three layers, 200 mg/Nm^3 ($\sim 0.8 \text{ lb/t}$) of NO_x is achieved from an inlet of $1,050 \text{ mg/Nm}^3$ (4.2 lb/t) or 80% control. The ammonia slip is less than 1 mg/m^3 . At the end of 2003, the catalyst had logged 20,000–25,000 hours with no discernable problems. The catalyst was guaranteed for 16,000 hrs, with an expected catalyst life of 3–4 yrs.

NO_x standards are 1000 mg/Nm^3 on a half-hour basis and 500 mg/Nm^3 on daily basis. (~ 4.6 and 2.3 lb/t , respectively). The plant emits less than 2.3 lb/t on 95.6% of operating days.⁵

Prior to installing the SCR system, the Solnhofen plant, was achieving 700 – 800 mg/Nm^3 (~ 2.8 – 3.2 lb/t) with SNCR. With SCR, the plant has been achieving 200 mg/Nm^3 (0.8 lb/t). Based on uncontrolled NO_x emission rate of $1,050 \text{ mg/Nm}^3$ (4.2 lb/t), the controlled emission rate corresponds to a NO_x control efficiency of 80%. Greater than 80% control is frequently achieved. According to equipment vendor KWH Catalyst, Inc. of Germany, the problem of fouling from heavy dust loading has proven to be quite manageable with regular catalyst cleaning. The gas temperature inlet to the SCR unit is 320 – $340 \text{ }^\circ\text{C}$ (610 – $640 \text{ }^\circ\text{F}$).^{2, 9}

The plant has continuous emission monitors (CEMs) for chlorides, PM, SO_2 , NO_x and Hg. The kiln also has an SO_2 standard of 0.23 lb/t on daily basis. This value is met 100% of the time. In this cement plant, the SO_3 formed at the location of the catalyst subsequently reacts with limestone in the raw mill. Also, the catalyst efficiently utilizes ammonia (including ammonia in the raw material), so it is not available for detached plume formation.¹⁰

The facility achieves NO_x reductions by using a combination of a low NO_x burner, alternative/waste fuels and either SNCR or SCR. The SNCR and SCR systems do not operate simultaneously. The LNB and alternative/waste fuels reduced NO_x by 40% (from baseline of $1,500$ – $1,800 \text{ mg/Nm}^3$ to 800 – $1,200 \text{ mg/Nm}^3$). Using SNCR or SCR further reduces NO_x by approximately 50%. The facility achieves the current NO_x emission limit of 500 mg/Nm^3 (a 70% reduction from uncontrolled baseline). This limit is a 24-hour average and was issued in 2002 when the facility operating permit was issued. The SCR construction permit has a goal of 200 mg/Nm^3 ; however, the facility has not achieved this level.⁴

The slipstream pilot test unit tested various plate catalyst. The dust loading in the preheater gas (80 – 100 g/Nm^3), and pressurized cleaning eroded the catalyst from the metal substrate. Within 1,000 hours, the reactivity of catalyst was not acceptable.

When the full-scale SCR system was constructed, a honeycomb catalyst was installed. In this high-dust operation, the catalyst plugged within minutes of commencing SCR operation. Eventually, the facility completed the custom manufacturing and testing of honeycomb catalysts with larger pitch and with various catalyst formulations. The first SCR layer contains honeycomb catalyst with a 13 mm pitch. The third and fifth layers contain honeycomb catalysts with 10 mm pitch. The second, fourth, and sixth layers are empty. The seventh layer contains a heat exchanger, which preheats the air utilized for pressurized cleaning.

Each catalyst bed contains six modules. Each of these modules contains 1444 catalyst elements in a 12 x 12 arrangement. The total depth of each catalyst layer is 35.4 inches. A bypass duct allows the facility to bypass the SCR system whenever temperature or pressure drop requires a bypass.

When operating the SCR system, the facility injects a 25% by weight ammonia in water solution, not in the inlet to system as is typical of power plant applications, but rather to the preheater between the second and third cyclones where the gas temperature is 550 °C (1,020 °F). The facility believes this location allows for the best distribution of ammonia in the flue gas, resulting in the most efficient SCR operation and lowest ammonia slip. If SNCR is used instead of SCR, the ammonia is injected into the preheater where the gas temperature is approximately 1,000 °C (1,830 °F).

The most recent catalyst cleaning system utilizes preheated compressed air that continuously cleans the catalyst. Dry compressed air at about 900 m³/hr at 10 bar pressure passes through a heat exchanger coil located in the seventh stage of the SCR reactor and then passes through insulated lines to each stage/layer of the reactor. Then, the air passes into the reactor, where a series of nozzles are located on two parallel bars that span the width of the reactor. The full cross-sectional area of the catalyst is reached by the cleaning system. Hydraulics are used to move the bars back and forth across the catalyst bed. The speed of the traverse is controlled electronically and can be adjusted when the pressure drop across the reactor begins to rise. The system cycles every 20 minutes and cleans the catalyst in sequence. Every 3,000–4,000 hours, the facility bypasses the SCR to perform additional, more thorough cleaning. This cleaning system took two to three years to conceptualize, construct, and modify.

The facility considers the SCR setup reasonably reliable. The plant manager is attempting to find a catalyst manufacturer to produce a plate catalyst with a formulation producing more durability. However, plate catalysts have less surface to volume ratios and less NO_x reduction capability for identical formulations used in honeycomb catalysts. The plant manager indicated that the most recent honeycomb catalyst has lasted 40,000 hours.

10.4.2 Cementeria di Monselice – Italy

ELEX constructed a full-scale SCR system at Cementeria di Monselice in Bergamo, Italy. The unit began operation in June 2006. The system's design is similar to the configuration at the Solnhofen plant, and the facility is similar to Solnhofen in size and raw materials.

The SCR system is guaranteed by ELEX to reduce NO_x by 90% from 2,000 to 200 mg/m³ (uncorrected).¹¹ In the future, the Monselice operator could theoretically decide to operate at levels closer to the permitted limit of 800 mg/m³ and perhaps start at lower baseline concentration, removing only about 50% of the NO_x.

The plant produces pure Type 1 cement (pure ground clinker), as well as various Type II cements and pozzolanic cement. Raw materials are primarily limestone and clay. The principal fuels are coal and petroleum coke. The NO_x limit is 800 mg/Nm³ (~2.5 lb/t). Lower NO_x emission limits have been set for new projects. For example, the limit at the Italcementi modernization in Bergamo is 500 mg/Nm³ (~1.4 lb/t).¹²

The kiln is a preheater kiln with a capacity of 100 t/hr. As shown in Table 6-1 of this report, preheater kilns have higher uncontrolled NO_x emissions than PH/PC kilns. The SCR system is a high-dust SCR (i.e., the SCR system is before the PM controls, ESP). The unit is installed after the preheater, where the gas temperature is typically 320–350 °C. The aqueous ammonia solution is injected in the gas stream below the uppermost preheater cyclone.

There are six catalyst layers. One layer is designed as a spare. Presently, only three layers are loaded with catalysts because the present kiln capacity is 75 t/hr. Catalyst activity remains high after 3,500 hours of operation.

Following startup in June 2006, continuous testing was conducted for six weeks. The results of these tests are summarized in Table 10-1.

Table 10-1. SCR Tests – 2006 – Cementerie di Monselice¹²

Parameter	Units	Design	Actual*
Kiln capacity	t/day	2,400	1,800
Gas flow	m ³ /h norm; wet	160,000	110,000
NO _x inlet	mg/dscm	2,260	1,530/1,070
Molar ratio	NH ₃ /NO _x	0.905	0.89/0.2
NO _x outlet	mg/dscm @ actual O ₂	232	75/612
NO _x stack	Same as above	200	50/408
NO _x removal	percent	90	95/43
NH ₃ slip	mg/dscm	< 5	< 1/< 1
O ₂ reactor	percent	2.5	2.7
O ₂ stack	percent	5.0	7.1/8.8 (compound)
Pressure drop	Millibars	15	< 5
NH ₄ OH	25 percent solution; kg/h	445	204/34

* Two separate sets of data were collected for most parameters.

Fuel burn during the tests was typically 80% petroleum coke blend with various types of coal as backup fuel. After this testing, the set point for NO_x is usually at 400 mg/m³. For testing and demonstrations, NO_x is lowered to below 100 mg/m³. Also during these tests, VOC was oxidized by 75%. NH₃ emissions before SCR operation were 25–50 mg/ m³. The ammonia in the raw material is consumed in the SCR process.¹²

10.5 ISSUES/SOLUTIONS USING SCR AT CEMENT KILNS – SAINT LAWRENCE CEMENT EXPERIENCE

St. Lawrence Cement (SLC) proposed to construct a new PH/PC kiln at their facility in Greenport, NY. Recently, SLC has decided not to construct this kiln. The following summarizes information developed during this process. This information is useful as it presents what some

believe are problems with the use of SCR in cement kiln sand responses to these apparent problems.

Most SCR systems are designed to operate between 315–390 °C (600–750 °F). For the Greenport project, the SCR system would have been located downstream of the preheater cyclones and prior to the roller mill. According to the Mechanical Process Flow Sheet prepared by Krupp, the process exhaust temperature is 320 °C (608 °F) at this location, which is ideal for SCR. Also, it was believed that SCR would not interfere with or affect the cement manufacturing process.¹³

The following presents various problems/issues that SLC raised to the State of New York that may occur if SCR was required for this cement kiln. A contractor to the Friends of the Hudson (FOH) provided responses to these concerns to the State of New York. Further, issues and responses on this subject that are contained in the Ellis County report⁷ are also discussed.

10.5.1 SO₂ Oxidation

SLC believed there were detrimental impacts due to significant levels of SO₃ in the SCR flue gas due to the oxidation of SO₂ by SCR catalyst. According to SLC, this can cause catalyst pore masking, the formation of ammonium salts that can plug downstream equipment, and acid mist emissions.¹⁴

SLC stated that high SO₃ concentrations could lead to catalyst deactivation and other serious problems relating to SO₂ oxidation. A high SO₃ concentration (10–20 ppmv), when coupled with the high calcium level in the cement kiln flue gas, could purportedly cause deactivation of the SCR catalyst due to the masking effect of calcium sulfate. In addition, any SO₃ that does not react with the calcium could react with any unused NH₃ to form ammonium sulfate or ammonium bisulfate and cause fouling of downstream equipment. Sulfur in the raw meal can be in several forms: calcium sulfate, magnesium sulfate, and sulfites such as pyrites or organically bound sulfur. Only the volatile sulfur compounds (namely the sulfides and organically bound sulfur) are oxidized and released in the preheater as SO₂.⁹

FOH responded that SCR used at a number of coal-fired boilers show that SCR systems can be designed for high calcium and high sulfur flue gases. SCR catalyst suppliers have indicated that CaSO₄ formation does not pose a major concern because they believe that the SO₃ generated in the process is captured by the free CaO in the gas stream. Thus, SO₂ oxidation by the catalyst will have no negative impact on the amount of SO₃ formed and subsequently captured.

FOH responded that SCR's success indicated that the SCR process eliminates 50–70% of SO₂. It is unclear where in the process the SO₂ removal occurred. The SO₂ removal could occur due to adsorption of SO₂ in the baghouse that replaced an ESP.¹³

Also, the catalyst at Solnhofen has completed 24,000 hours of operation without any plugging problems or acid mist emissions. The presence of high SO₃ concentration has not led to catalyst deactivation and other problems at facilities with high calcium and high sulfur flue gases based on experience at various coal-fired plants.¹⁵

10.5.2 High CaO Loading and Potential Masking – CaSO₄ Formation

SLC believed that SO₃ oxidation could lead to catalyst masking by CaSO₄ formation and the generation of significant levels of sulfuric acid mist. SLC at Greenport will have SO₂ concentration of 177 mg/Nm³ (600 ppmv) in the preheater exhaust gas. With 0.5–2.0% SO₂ oxidation, a high SO₃ concentration of 8–17 ppmv could result. This high SO₃ concentration, along with the high calcium level in the cement kiln flue gas, would deactivate SCR catalyst due to masking effects of calcium sulfate.¹⁴

FOH responded that catalyst plugging problems can be prevented by managing the type and frequency of soot blowing and by using a heated, compressed air blowing system.¹³

10.5.3 Ammonium Bisulfate⁷

SLC stated that SO₃ that does not react with calcium would react with any ammonia slip from the SCR unit to form ammonium sulfate or ammonium bisulfate, which could cause fouling of downstream equipment. According to SLC, Solnhofen has not had to face SO₃ concentrations of this magnitude because inlet SO₂ is so low.¹⁴

Also, it is argued that ammonium salts could increase condensable PM levels, making it difficult for a facility to meet its PM limits.⁹

In SCR systems with SO₂, NH₃, and moisture present, ammonium salts will form at temperatures below 300–310 °C (580–590 °F). The best way to prevent their formation is to continuously control the SCR inlet temperature such that it is always 310 °C (600 °F) or greater. Regarding the possible release of SO₃, catalyst manufacturers report that SO₃ gas is totally captured by conversion to particulate calcium sulfates and sulfites because it is contacted by free CaO upstream, within, and downstream of the SCR catalyst. Thus, the formation of undesirable byproducts should be inherently controlled by the free CaO in the system and can be further controlled by controlling the SCR inlet temperature.^{7,13}

FOH responded that ammonium salts will form at temperatures below 304–310 °C (580–590 °F). The plant can continuously monitor SCR inlet temperature to assure that the temperature is always 315 °C (600 °F) or greater.⁷ Another option is the use of a cyclone preheater bypass duct.¹⁴ Also, Solnhofen has much higher SO₂ emissions than SLC estimates (between 733–1,700 mg/Nm³).¹⁵

Alstom guarantees SO₃ oxidation rate of 0.5%. Also, the rate of CaSO₄ formation must be considered. Any SO₃ formed would have to diffuse through gas film surrounding the CaO particle, then diffuse into the CaO particle, and finally react with CaO to form CaSO₄. These reactions take considerable time (several hours). Soot blowers can remove CaO dust on catalyst every 15–20 minutes to help prevent CaSO₄ formation in catalyst pores.¹⁵

10.5.4 Water Soluble Alkali – Alkali Poisoning – Catalyst Deactivation^{7,9,14}

SLC believed that there is a need to look at the total quantity of poisons and availability of catalyst poisons reaching the vanadium pentoxide in the SCR catalyst.¹⁴

Poisoning occurs when contaminants in the gas being treated react with the catalyst, resulting in catalyst deactivation. It's been argued that SCR in a cement plant will be subject to poisoning, principally from sodium, potassium, and arsenic trioxide. Phosphorous, chromium, and lead compounds can also poison an SCR catalyst, but these are expected to be present in lower concentrations at cement kilns. However, the typical concentration of sodium oxide in the PM of certain coal-fired utilities is greater than double the Na_2O concentrations in the PM of the average cement plant. Also, the maximum Na_2O concentration in the PM emissions from coal-fired utility boilers can be significantly greater than the maximum expected concentration of Na_2O in the average cement plant emissions. Similarly As_2O_3 concentration of flue gas of typical coal-fired plant is well above the typical concentration expected from the average cement plant.^{7,9}

10.5.5 The Solubility of Sodium and Potassium in the Fly Ash and the Form of Fly Ash Particles^{7, 12-15}

SLC argued that in PH/PC kilns, materials such as sodium and potassium compounds may be present in relatively elevated concentrations on particle surfaces in “water soluble” form that can contact the SCR surface of the catalyst bed and poison the V_2O_5 “active ingredient.” It is argued that in coal-fired boilers, the sodium and potassium are, to a major extent, trapped within a glass-like fly ash particle. It is widely known, however, that fly ash particles from coal-fired boilers are in the form of tiny spheres and, during combustion, the particles are actually liquid and spheres formed as tiny bubbles by evolved gases trying to escape. Boilers are designed to cool the molten particles to a solid state so that they can be easily removed from boiler tubes. However, depending on the fly ash temperature and its chemical composition, some fly ash will deposit in various sections of the boiler. The deposits that form at the back end of the boiler (on the economizer and air heater) are called “low-temperature deposits.” Low-temperature deposits are usually characterized by low pH; many contain hydrated salts and, for most bituminous coals, are water soluble. Therefore, coal-fired boilers do have fly ash deposits in the economizer section of the boiler that are water soluble; however, deactivation has not been found to occur. Also, SCR systems have been installed on oil-fired boilers despite the relatively higher levels of water-soluble alkaline metals found in the fly ash from such boilers.^{7, 13}

FOH stated that data from a Kansas City coal fired power plant with SCR has more than double the Na_2O concentration in PM. Also, there is 2.3–2.5 times the As_2O_3 concentration at the Somerset unit with SCR.¹⁵

The corrosive layer of fly ash deposits is fly ash with Na_2O concentrations of 0.1–14% and K_2O levels of 0.2–3.0%. These compounds are water soluble. The predominance of SO_3 gives fly ash deposits their acidic property, although water-soluble alkali is still present in significant concentrations. Thus, fly ash from coal-fired boilers contains water-soluble alkali that could deactivate an SCR catalyst. SCR catalysts on coal-fired boilers have not been deactivated from alkali poisoning because catalyst suppliers have developed catalysts and SCR systems that address this problem.¹⁵

Sticky deposits are primarily due to alkali salts (primarily potassium and sodium chloride and sulfates), which will be significantly removed by the alkali bypass system. Also, Alstom, an

SCR equipment supplier, stated that sticky deposits can be addressed through the type and frequency of soot blowing.^{7, 15}

Various coal-fired plants have successfully used SCR despite concentrations of various catalyst poisons higher than those expected at Greenport plant. Oil-fired boilers are using SCR despite the presence of water-soluble fly ash, suggesting that alkali in cement kiln fly ash is unlikely to deactivate the catalyst.¹⁵

SLC stated that alkali from coal combustion is trapped in glass-like ash particles and is therefore unavailable to poison the catalyst.¹⁴

FOH replied that no analytical or quantitative data was provided to evaluate this comment. Fly ash from coal-fired boilers are dispersed in the form of tiny spheres that during coal combustion are actually liquid.^{12, 15}

SLC also stated that potassium, the main form of alkali in Greenport, is usually not considered a water-soluble alkali with respect to the sintered fly ash deposits.

FOH responded that potassium is present in coal-fired boiler fly ash and, hence, would be available to deactivate SCR catalysts. However, SCR catalysts on coal-fired boilers have not undergone catalyst deactivation from alkali poisons.¹²

10.5.6 High-Dust Loadings^{7, 14, 15}

SLC wrote that larger SCR systems do not have the high-dust loadings expected at the Greenport facility.¹⁴

According to FOH, Kansas City Power & Light has one half the dust loading at Greenport (32.7g/Nm³ vs. 60 g/Nm³). Also, the gas-flow rate is 23 times the proposed Greenport unit (8,860,000 Nm³/hr vs. 381,000 Nm³/hr).¹⁵ In addition, Solnhofen operates at dust load of 80 g/Nm³, which is 20 grams higher than the loading anticipated for Greenport.¹⁵

The presence of alkali in cement kilns is a factor in the build up of sticky deposits, i.e., extremely hard, layered, brick-like build up associated with the impingement of PM at high velocity against the rotating parts of the fan impeller. To avoid build-up, one recommendation is to select a fan that minimizes the gas/dust velocity at the fan rotor inlet. Alternatives include using double inlet fans or using larger diameter, lower RPM fans. Sticky deposits or build up developing on other parts of the cement kiln system are not common. Thus, the sticky deposit problem appears to be related solely to the ID fan and is due to high-impact velocity of the dust particles mostly on the fan. This problem should not affect an SCR catalyst that is subject to comparatively low gas velocities in comparison to an ID fan.⁷

For instance, gas velocities through an SCR system are typically less than 6.2 m/sec (1,220 ft/min); whereas the peripheral gas speed at the kiln ID fan rotor inlet is approximately 15,000 ft/min. Possible problems relating to thermal sintering have been addressed by advances in catalyst technology and proper system design. The problem of thermal sintering has been avoided by incorporating tungsten in catalyst and by a bypass around SCR so that the catalyst is not exposed to high-temperature excursions. Hardening the leading edge of the catalyst and

arranging the catalyst bed so that airflow is parallel to catalyst channels have addressed catalyst erosion.⁷

10.5.7 NO_x Inlet Variability/NH₃ Slip^{7, 12, 14, 15}

SLC stated that NO_x variations are greater at cement kilns than for power plants. Also, there are considerable differences among cement kilns. SLC stated that it was impossible to draw conclusions from information on one plant.¹⁴

FOH replied that this NO_x variability has greater risk in SLC's proposed MSC and SNCR systems than for SCR. An SNCR system must instantly increase the ammonia feed rate in direct proportion to NO_x concentration, whereas the SCR catalyst acts like a reservoir to store excess ammonia, which is able to handle sudden peaks in inlet NO_x concentration.¹²

SLC was not aware of any data that quantifies the extent of the ammonia reserve and compares this on a mole basis to the duration and magnitude of NO_x concentration spikes in cement kilns.¹⁴

According to FOH, equipment vendors KWH and Alstom each guarantee a low ammonia slip of 2 ppmvd. Solnhofer's achieves NO_x emissions of 500 mg/Nm³ (2.3 lb/t) and less than 1 mg/Nm³ of ammonia.¹⁵

Coal-fired boilers have been operating SCR systems successfully for years despite considerable NO_x fluctuations in their flue gases. SCR suppliers typically guarantee a NH₃ slip of < 2 ppmv for any coal-fired boiler. Also, the Solnhofen data indicates that with all of inherent variability, they have achieved a high degree of NO_x control with low ammonia slip. Data indicates SCR inlet varies from 4.6–9.3 lb/t (1,000–2,030 mg/Nm³), whereas the outlet varies from 1.4–3.3 lb/t (300–726 mg/Nm³). Average outlet NO_x concentration is less than 2.3 lb/t (500 mg/Nm³); however, at these variable conditions, NH₃ slip has been maintained in 1–2 ppmv range.^{7, 9}

10.5.8 Catalyst Plugging/Fouling^{7, 9}

Catalyst plugging/fouling involves the accumulation of dust that blocks access to pores of the catalyst. It is argued that high-dust loadings could plug or foul the SCR catalyst beds; however, the Solnhofen SCR system has operated at a relatively high-dust loading (80 g/Nm³). The level of NO_x removal shows that high-dust loading can be managed to avoid catalyst plugging and fouling while maintaining high levels of control. Related to the plugging and fouling issues, it is argued that “sticky deposits” in preheater exhaust gas could foul and plug the SCR catalyst. Specifically, certain cement kiln operations could be prone to producing sticky deposits at exactly the temperature ranges in which SCR systems operate. As described earlier, sticky deposits are a widespread problem for cement kiln ID fans.

Sticky deposits or build-up developing on other parts of the cement kiln system are not common. This problem should not affect an SCR catalyst that is subject to comparatively low gas velocities in comparison to an ID fan.

10.5.9 Temperature-Related Factors Leading to Lower SCR NO_x Removal Efficiencies^{7,9}

Low temperatures can lead to lower NO_x reduction efficiencies and/or higher catalyst activity (leading to possible SO₂ oxidation) and to possible ammonium bisulfite/ammonium sulfate (ABS/AS) formation in the catalyst pores.

The following operating conditions will help to avoid temperature-related SCR problems:

- An acceptable normal operating temperature
- Even temperature distribution
- Avoiding temperature extremes (which may lead to catalyst deactivation or sintering).

To address the temperature concerns of a slightly lower than desirable temperature, equipment can be installed to ensure a temperature of at least 315 °C (600 °F) for flue gas entering the SCR system. Such control systems are commonly used on boiler air supply systems and economizer bypass ducts. The SCR reactor should also have an automatically activated bypass duct around the reactor so that during periods of high temperature fluctuations (> approximately 430 °C [800 °F]), automatically controlled dampers will send the hot flue gas to a reactor bypass duct, thus preventing any damage to the SCR catalyst.

To address normal operating temperatures and temperature fluctuations, FOH recommends that a bypass system be installed that would divert a quantity of gas from the gas duct between the fourth and fifth stages of the preheater.¹²

10.6 REFERENCES

1. U.S. Environmental Protection Agency. *Alternative Control Techniques Document – NO_x Emissions from Cement Manufacturing*. EPA-453/R-94-004. March 1994. Available at www.epa.gov/ttn/cata/dir1/cement.pdf.
2. Kossina, I. *Reduction of NO_x Emissions from Exhaust Gases of Cement Kilns by Selective Catalytic Reduction*. Dipl.-Ing. Proceedings of NO_x Conference, Paris. March 2001.
3. U.S. Environmental Protection Agency. *NO_x Control Technologies for the Cement Industry*. Prepared by EC/R Incorporated. September 19, 2000. Available at www.epa.gov/ttn/naaqs/ozone/ozonetech/cement_nox_update_09152000.pdf.
4. Portland Cement Association. *Report on NO_x Formation and Variability in Portland Cement Kiln Systems Potential Control Techniques and Their Feasibility and Cost Effectiveness*. PCA R&D Serial No. 2227. Prepared by Penta Engineering Corp. 1999.
5. Linero, A. *SNCR NO_x at US Cement Plants. Is SCR Close Behind?* Paper #638 presented at the AWMA Annual Conference. June 2005.
6. ELEX. Website: <http://www.elex.ch/doc/denox.pdf>. Accessed March 6, 2007.
7. Texas Commission on Environmental Quality. *Assessment of NO_x Emissions Reduction Strategies for Cement Kilns – Ellis County*. Final Report. Prepared by ERG. July 14, 2006. Available at www.tceq.state.tx.us/implementation/air/sip/BSA_settle.html.

DRAFT – DO NOT QUOTE OR CITE

8. U.S. Environmental Protection Agency. *11.6 Portland Cement Manufacturing*. AP 42, Chapter 11.6. Available at <http://www.epa.gov/ttn/chief/ap42/ch11/final/c11s06.pdf>.
9. Email transmission from A. Linero, Florida Department of Environmental Protection, to B. Neuffer, U.S. Environmental Protection Agency. *SCR – Cement Kilns*. March 28, 2005.
10. Friends of Hudson. *Summary of Research Concerning Applicability of Selective Catalytic Reduction to Control Emissions of Nitrogen Oxides from the Proposed St. Lawrence Cement Company Cement Manufacturing Facility in Hudson/ Greenport, New York*. Undated.
11. Email transmission from A. Linero, Florida Department of Environmental Protection, to B. Neuffer, U.S. Environmental Protection Agency. December 2006.
12. Leibacher, U., and A.A. Linero. “High Dust SCR Solutions.” *International Cement Review*. December 2006
13. St. Lawrence Cement. *Responses to Comments submitted by Friends of Hudson, Massachusetts Department of Environmental Protection and Connecticut Attorney General*. April 2004.
14. Friends of Hudson. *Response to St. Lawrence Cement’s Supplemental LAER Analysis*. March 24, 2004
15. Friends of Hudson. *Response to St. Lawrence Cement’s April 2004 SCR Comments*. July 8, 2004.

11.0 MULTIPOLLUTANT ASPECTS OF SELECTIVE NON-CATALYTIC REDUCTION (SNCR) AND SELECTIVE CATALYTIC REDUCTION (SCR)

Besides their ability to reduce emissions of NO_x, post-combustion controls, SNCR and SCR, reportedly have other impacts in the form of small increases or decreases in the emissions of other pollutants. For example, NH₃ slippage is a recognized effect with both technologies. This effect is more pronounced when higher molar ratios of NH₃/NO are used with SNCR to achieve greater NO_x removal efficiencies (approaching 200 mg NO_x/m³ or about 1 lb/t of clinker). The extent to which there are multipollutant impacts will vary among kilns and depend on factors unique to each kiln, including the nature of raw materials and kiln design and the operating conditions. A qualitative summary of the multipollutant effects associated with the application of SNCR and SCR controls to Portland cement manufacturing is presented in Table 11-1.

Table 11-1. Potential Multipollutant Effects of SNCR and SCR¹⁻⁹

Pollutant	SNCR	SCR
NH ₃	I	I/D (lower slippage than SNCR)
N ₂ O	I	
CO	I	D (debateable)
CO ₂	I	
PM ₁₀	I (due to ammonia slip)	I (due to ammonia slip; typically low)
SO ₂		D
H ₂ SO ₄ (or SO ₃)		I/D (SO ₃ created, but removed by PM control device; removed by PM control device prior to exhaust)
Hg		D (Hg ⁰ oxidized in the presence of chlorides)
VOC		D (may depend on catalyst)
Dioxin/Furan		D

Note: I - indicates a potential increase in the emissions of the pollutant. D - indicates a potential decrease in the emissions of the pollutant.

The claim of SCR reduction of CO emissions was made as part of a pilot test, but was not confirmed.⁵ SCR reductions in SO₂ emissions result from the conversion of SO₂ to SO₃ in the presence of the catalyst. The resulting SO₃ is removed by the particulate matter control device (fabric filter or ESP) at the cement plant so that SO₃ emissions do not increase.⁵ As mentioned above, increased emissions of PM₁₀ are associated with ammonia emissions, which are a precursor of fine particulate matter. The conversion of elemental mercury to oxidized mercury is

considered a benefit of SCR because oxidized mercury can be easily controlled using a wet scrubber, whereas elemental mercury is difficult to control.^{5,9}

11.1 REFERENCES

1. Haug, N., et. al. *New Development of High Dust – SCR Technology in the Cement Industry; Results of Pilot Tests in Solnhoffen and Development State of a Full Scale SCR Unit*. 5 pages. Undated.
2. Email transmission from A. Linero, Florida Department of Environmental Protection to B. Neuffer, U.S. Environmental Protection Agency. February 12, 2007.
3. Email transmission from S. Khan, U.S. Environmental Protection Agency, to B. Neuffer, U.S. Environmental Protection Agency. February 22, 2007.
4. Bolwerk, R., G. Ebertsch, M. Heinrich, S. Plickert, and M. Oerter. *German Contribution to the Review of the Reference Document on Best Available Techniques in the Cement and Lime Manufacturing Industries. Part II: Cement Manufacturing Industries*. Annex V and VI. June 1, 2006.
5. Email transmission from A. Linero, Florida Department of Environmental Protection, to B. Neuffer, U.S. Environmental Protection Agency. February 23, 2007.
6. Leibacher, U., C. Bellin, and A.A. Linero. High dust SCR solutions. *International Cement Review*. December 2006.
7. MacDonald, J.A. Controlling the NO_x after the burn. *Energy Tech Magazine*. December 1, 2002.
8. Institute of Clean Air Companies. *White Paper: Selective Non-Catalytic Reduction (SNCR) for Controlling NO_x Emissions*. May 2000.
9. Lee, C.W., R.K. Srivastava, S.B. Ghorishi, T.W. Hastings, and F.M. Stevens. *Study of Speciation of Mercury under Simulated SCR NO_x Emission Control Conditions*. Undated.

12.0 SNCR AND SCR COSTS

Costs for SNCR and SCR controls on PH/PC kilns are summarized in Table 12-1. Cost information was obtained from a variety of sources and is based on the cost of controls in cement kilns in the U.S. as well as Europe. Some costs represent the cost of retrofitting existing kilns and likely overstate costs compared to new kiln installations. Costs in Euros were converted to U.S. dollars. Where available, information on the year of the costs is included. In some cases, the year of the costs was specified in the reference. In a few instances, the year was estimated based on the dates of the documents containing the cost information, assuming the year of the costs might be expected to be similar to or somewhat earlier than the document date. An example would be cost information included as part of a permit application or other correspondence with a permitting agency. When available, both capital and annualized costs are presented, as well as the method of estimating costs. Both cost effectiveness, expressed as cost per unit of NO_x controlled (\$/t NO_x), and cost burden, expressed as cost per unit of clinker produced (\$/t of clinker), are presented. In order to make comparisons of the costs, the costs were scaled to 2005 using the Chemical Engineering Plant Cost Index as published in Chemical Engineering Magazine. Costs in 2005 dollars are shown in Table 12-2. For some of the costs presented in Tables 12-1 and 12-2, more detailed information is available in the references cited.

For SNCR's, cost effectiveness ranged from \$327 to \$5,222/t NO_x controlled, with a mean and median of approximately \$1,900 and \$1,400, respectively. The cost burden ranged from \$0.51 to \$2.52/t of clinker, with a mean and median of \$1.03 and \$0.93, respectively.

For SCR's, cost effectiveness ranged from \$1,300 to \$22,000/t NO_x controlled, with a mean and median of \$5,200 and \$2,000/t NO_x controlled, respectively. The cost burden ranged from \$0.92 to \$9.11/t of clinker, with a mean and median of \$2.82 and \$1.81/t of clinker, respectively. The highest cost effectiveness and cost burden values were due to the high cost of reheating the flue gas before entering the catalyst.

Capital costs for SNCR systems primarily include the cost of an injection system for the ammonia-based or urea-based reagent, the delivery system, reagent storage tanks, and control instrumentation. Operating costs include the costs of reagents and additives, electricity for reagent pumping, and fuel penalty cost along with operating labor and maintenance requirements. The primary annual cost component is ammonia.

SCR systems applied to cement PH/PC kilns can be either "low-dust" or "high-dust" systems depending on their location after or before the particulate matter control device. In both SCR systems, capital costs include the cost of the SCR catalyst and reactor and, like the SNCR system, the reagent delivery system, storage and instrumentation. Because of the problems of catalyst plugging, the high-dust system requires a catalyst cleaning mechanism, such as pressurized air nozzles or sonic horns. The low-dust system avoids costs associated with catalyst cleaning. Similar to SNCR, operating costs include operating labor and maintenance costs, reagent costs and electricity of reagent pumping. Additional electrical costs are also incurred due to an increase in pressure drop caused by the catalyst. High-dust SCR systems incur higher energy costs for catalyst cleaning. Operating cost also include catalyst replacement every few years.

Table 12-1. SNCR and SCR Costs for Preheater/Precalciner Kilns

No.	Kiln	Retrofit (R) or New (N) Installation	Prod Rate, t/hr (t/yr)	Uncont. Emission Rate	Cont. Emission Rate	NO _x Reduction (%)	Yr of Cost	Capital Cost (\$)	Annualized Cost (\$)	Cost Effect. (\$/t NO _x)	Cost Burden (\$/t clinker)	Costing Method	Ref.
Selective Noncatalytic Reduction (SNCR)													
1	Model (urea)	R	100 (750000)	1360 t/yr	680 t/yr	50	1992	969,000	598,000	880	0.80		1 ^a
2	Model (urea)	R	150 (1125000)	2040 t/yr	1020 t/yr	50	1992	1,240,000	820,000	800	0.73		1
3	Model (NH ₃)	R	100 (750000)	1360 t/yr	680 t/yr	50	1992	1,650,000	665,000	980	0.89		1
4	Model (NH ₃)	R	150 (1125000)	2040 t/yr	1020 t/yr	50	1992	2,110,000	894,000	880	0.79		1
5	Kiln A	R	92 (736000)	340 lb/hr	204 lb/hr	40	1997	1,060,000	560,000	1,000	0.76	EPA Cost Manual	2 ^b
6	Kiln B	R	133 (1064000)	510 lb/hr	306 lb/hr	40	1997	1,200,000	2,000,000	2,500	1.88	EPA Cost Manual	2
7	Kiln	R				10–50	2004			310–2500			3 ^c
8	Kiln (NH ₃ reagent)	R					1998	610000–1820000			0.46–0.90		4 ^{c,d}
9	Kiln (urea reagent)	R					1998	610000–1210000			1.33–2.1		4 ^{c,d}
10	4 Kilns	R	1500, 2500, 3500, 5000 t/day				2004			1700–2300	0.61–0.85		5 ^{c,d}

(continued)

Table 12-1. (continued)

No.	Kiln	Retrofit (R) or New (N) Installation	Prod Rate, t/hr (t/yr)	Uncont. Emission Rate	Cont. Emission Rate	NO _x Reduction (%)	Yr of Cost	Capital Cost (\$)	Annualized Cost (\$)	Cost Effect. (\$/t NO _x)	Cost Burden (\$/t clinker)	Costing Method	Ref.
Selective Noncatalytic Reduction (SNCR) (continued)													
11	Suwannee American Cement, Branford, FL	N					No date			1250			6
12	Slite	N		1200 mg/m ³	200 mg/m ³	80	1999	1,330,000		330	0.66		7 ^{c,d,e,f}
13	Calciner kiln (urea)	R	150	700 lb/hr (>500ppm)	385 lb/hr	45	1999	400,000–800,000		675	0.71		8 ^{c,g}
14	Holcim #1	R		2,222 t/yr	1,111 t/yr	50	2006			1400	1.18	EPA Cost Man. & OTAG	9 ^h
15	Holcim #2	R		1,778	889 t/yr	50	2006			1600	1.09	do	9 ^h
16	TXI #5	R		1,710	1,112	35	2006			2300	0.55	do	9 ^h
17	3500 mt/day kiln	R	3858 t/day	850 mg/m ³	250 mg/m ³	70	2004	1,153,000		465	0.64		10 ^{c,i}
18	Calciner	N	100	3.4 lb/t	2.4	30	1997	1,300,000	930,000	2400			11
19	Calciner	N	150	3.4 lb/t	2.4	30	1997	1,700,000	1,200,000	2100			11
20	Calciner w/ alkali bypass	N	150	3.4 lb/t	2.4	30	1997	2,100,000	1,600,000	2700			11
21	Holcim, Lee Island, MO	N		4.0 lb/t	2.6 lb/t	35	2001			3833			12 ^c

(continued)

Table 12-1. (continued)

No.	Kiln	Retrofit (R) or New (N) Installation	Prod Rate, t/hr (t/yr)	Uncont. Emission Rate	Cont. Emission Rate	NO _x Reduction (%)	Yr of Cost	Capital Cost (\$)	Annualized Cost (\$)	Cost Effect. (\$/t NO _x)	Cost Burden (\$/t clinker)	Costing Method	Ref.
Selective Noncatalytic Reduction (SNCR) (continued)													
22	Drake Cement, AZ	N		840 t/yr	588 t/yr	30	2004		1,060,000	4211			13 ^c
23	Drake Cement, AZ	N		840 t/yr	588 t/yr	30	2003	1,400,000	1,130,000	4480			14 ^c
24	Florida Rock, Newberry, FL	R		4.0 lb/t	2.0 lb/t	50	2003				0.82		15 ^c
25	Florida Rock, Newberry, FL	R		3.5 lb/t	2.0 lb/t	43	2003				0.60		15 ^c
26	Florida Rock, Newberry, FL	R		3.5 lb/t	2.4 lb/t	43	2003				0.50		15 ^c
27	IEEE Mtg	R				400–800 t/yr	2001	360,000– 720,000	360,000– 720,000	900–1800			16 ^c
28	Proposed kiln, CEMEX #3, FL	N	3850 t/day	3.5 lb/t	1.95 lb/t		2005	350,000 (0.20– 0.25/t clinker)	0.40–0.65/ t clinker	470–500			17 ^{cj}
Selective Catalytic Reduction (SCR)													
29	Holcim #1	R		2,222 t/yr (3.4 lb/t)	333 t/yr (0.50 lb/t)	85	2006			1600	2.36	EPA Cost Man.	9 ^h
30	Holcim #2	R		1,778 t/yr (2.7 lb/t)	267 t/yr (0.41 lb/t)	85	2006			1900	2.00	Do	9 ^h

(continued)

Table 12-1. (continued)

No.	Kiln	Retrofit (R) or New (N) Installation	Prod Rate, t/hr (t/yr)	Uncont. Emission Rate	Cont. Emission Rate	NO _x Reduction (%)	Yr of Cost	Capital Cost (\$)	Annualized Cost (\$)	Cost Effect. (\$/t NO _x)	Cost Burden (\$/t clinker)	Costing Method	Ref.
Selective Catalytic Reduction (SCR) (continued)													
31	TXI #5	R		1,710 t/yr (1.4 lb/t)	342 t/yr (0.27 lb/t)	80	2006			2000	1.00	Do	9 ^h
32	3500 mt/day kiln	R	3858 t/day	850 mg/m ³	250 mg/m ³	70	2004	8,320,000		1230	1.69		10 ^{c,i}
33	Model	R	100	1360 t/yr	270 t/yr	80	1992	19,300,000	5,300,000	4900		-- ^k	1
34	Model	R	150	2040	410	80	1992	24,600,000	7,180,000	4400		-- ^k	1
35	Kiln	R				70–90+	2004			1500–2000			3 ^c
36	Kiln	R	70 (529,000 t/yr)	800 mg/m ³	200 mg/m ³		2004				1.21		18 ^{c,l}
37	Suwannee American	N	127 (1,055,000 t/yr)	1320 t/yr (2.5 lb/t)	898 t/yr (1.7 lb/t)	32	2004	4,600,000	9,100,000	21,000 (5,400 without reheating costs)	8.64 (2.18 without reheating costs)	Similar to EPA Cost Man	19 ^{c,m}
38	Sumter Cement, New Center Hill, FL	N		2404 t/yr	1460t/yr (1.7 lb/t)	39	2004	5,500,000	9,600,000	10,200 (3,000 without reheating costs)	5.58	Similar to EPA Cost Man.	20 ^{c,n}

(continued)

Table 12-1. (continued)

No.	Kiln	Retrofit (R) or New (N) Installation	Prod Rate, t/hr (t/yr)	Uncont. Emission Rate	Cont. Emission Rate	NO _x Reduction (%)	Yr of Cost	Capital Cost (\$)	Annualized Cost (\$)	Cost Effect. (\$/t NO _x)	Cost Burden (\$/t clinker)	Costing Method	Ref.
Selective Catalytic Reduction (SCR) (continued)													
39	VDZ	R	1500, 2500, 3500, 5000 t/day				2004				1.21–2.30		5 ^{c,d}
40	Proposed kiln, CEMEX #3, FL	N	3850 t/day	3.5 lb/t	1.95 lb/t	44	2005	6,200,000	2,000,000	2000	1.55	See footnote	17 ^{c,o}

^a Hrs of operation: 7500 hr/yr.

^b Hrs of operation: 8000 hr/yr.

^c Year of cost is estimated from date of reference.

^d Euros converted to dollars using \$1.21/Euro.

^e Capital cost = installation cost (\$0.67M) + reagent storage cost (\$0.67M)

^f Cost per ton reported as 0.3 euro/kg NO_x = (\$1.21/euro x 0.3 euro)/(0.0011 ton/kg = \$330/t)

^g Cost based on 85% capacity

^h Original burden cost reported as \$/mt. Converted to short ton (ton) using 1.1 ton/mt.

ⁱ Conversion apparently using ~\$1.31/euro; costs supplied in a 2/1/07 email from Al Linero, Florida DEP.

^j Capital cost is total installed SNCR costs; annualized costs is annual operating cost including capital recovery.

^k Cost based on equipment cost estimate from Japanese supplier to US cement company for a dry long 47 t/hr kiln.

^l Assumes 7500 hr/yr

^m \$6.8 million of the annualized cost is for the reheating of the flue gas. Operates 8,322 hrs/yr.

ⁿ \$6.77 million of the annualized cost is for the reheating of the flue gas.

^o Cost are estimates from German Federal Environmental Office and scaled to CEMEX kiln. Capital cost is the installed cost plus catalyst cost (based on European costs); annualized cost estimated using EPA methods and catalyst replacement every 4 yrs. Clinker production cost is \$50/t.

Table 12-2. SNCR and SCR Costs for Preheater/Precalciner Kilns in 2005 Dollars

No.	Kiln	Prod Rate, t/hr (t/yr)	Uncont. Emission Rate	Cont. Emission Rate	NO _x Reduction (%)	Original Yr of Cost	Annualized Cost (\$)	Cost Effect. (\$/t NO _x)	Cost Burden (\$/t clinker)	Costing Method	Ref.
Selective Noncatalytic Reduction (SNCR)											
1	Model (urea)	100 (750000)	1360 t/yr	680 t/yr	50	1992	754,192	1,109	1.01		1
2	Model (urea)	150 (1125000)	2040 t/yr	1020 t/yr	50	1992	1,037,307	1,017	0.93		1
3	Model (NH ₃)	100 (750000)	1360 t/yr	680 t/yr	50	1992	822,422	1,209	1.10		1
4	Model (NH ₃)	150 (1125000)	2040 t/yr	1020 t/yr	50	1992	1,109,328	1,087	0.98		1
5	Kiln A	92 (736000)	340 lb/hr	204 lb/hr	40	1997	678,375	1,211	0.92	OAQPS Cost Manual	2
6	Kiln B	133 (1064000)	510 lb/hr	306 lb/hr	40	1997	2,422,768	3,028	2.28	OAQPS Cost Manual	2
7	Kiln				10–50	2004		327–2,635			3
8	Kiln (NH ₃ reagent)					1998			0.55–1.08		4
9	Kiln (urea reagent)					1998			1.60–2.52		4
10	4 Kilns	1500, 2500, 3500, 5000 t/day				2004		1800–2400	0.64–0.90		5
11	Suwannee American Cement, Branford, FL					No date					6

(continued)

Table 12-2. (continued)

No.	Kiln	Prod Rate, t/hr (t/yr)	Uncont. Emission Rate	Cont. Emission Rate	NO _x Reduction (%)	Original Yr of Cost	Annualized Cost (\$)	Cost Effect. (\$/t NO _x)	Cost Burden (\$/t clinker)	Costing Method	Ref.
Selective Noncatalytic Reduction (SNCR) (continued)											
12	Slite		1200 mg/ m ³	200 mg/ m ³	80	1999		396	0.79		7
13	Calciner kiln (urea)	150	700 lb/hr (>500ppm)	385 lb/hr	45	1999		809	0.82		8
14	Holcim #1		2,222 t/yr	1,111 t/yr	50	2006		1,288	1.09	OAQPS Cost Man. & OTAG	9
15	Holcim #2		1,778	889 t/yr	50	2006		1,472	1.00	do	9
16	TXI #5		1,710	1,112	35	2006		2,116	0.51	do	9
17	3500 mt/day kiln	3858 t/day	850 mg/ m ³	250 mg/ m ³	70	2004		490	0.67		10
18	Calciner	100	3.4 lb/t	2.4	30	1997	1,126,587	2,907			11
19	Calciner	150	3.4 lb/t	2.4	30	1997	1,453,661	2,544			11
20	Calciner w/ alkali bypass	150	3.4 lb/t	2.4	30	1997	1,938,215	3,271			11
21	Holcim, Lee Island, MO		4.0 lb/t	2.6 lb/t	35	2001		4,040			12
22	Drake Cement, AZ		840 t/yr	588 t/yr	30	2004	1,117,271	4,439			13
23	Drake Cement, AZ		840 t/yr	588	30	2003	1,317,067	5,222			14
24	Florida Rock, Newberry, FL		4.0 lb/t	2.0 lb/t	50	2003			0.96		15

(continued)

Table 12-2. (continued)

No.	Kiln	Prod Rate, t/hr (t/yr)	Uncont. Emission Rate	Cont. Emission Rate	NO _x Reduction (%)	Original Yr of Cost	Annualized Cost (\$)	Cost Effect. (\$/t NO _x)	Cost Burden (\$/t clinker)	Costing Method	Ref.
Selective Noncatalytic Reduction (SNCR) (continued)											
25	Florida Rock, Newberry, FL		3.5 lb/t	2.0 lb/t	43	2003			0.70		15
26	Florida Rock, Newberry, FL		3.5 lb/t	2.4 lb/t	43	2003			0.58		15
27	IEEE Mtg				400–800 t/yr	2001	427,000– 855,001	1,069–2,137			16
28	Proposed kiln, CEMEX #3, FL	3850 t/day	3.5 lb/t	1.95 lb/t		2005		470–500			17
Selective Catalytic Reduction (SCR)											
29	Holcim #1		2,222 t/yr (3.4 lb/t)	333 t/yr (0.50 lb/t)	85	2006		1,472	2.17	OAQPS Cost Man.	9
30	Holcim #2		1,778 t/yr (2.7 lb/t)	267 t/yr (0.41 lb/t)	85	2006		1,748	1.84	Do	9
31	TXI #5		1,710 t/yr (1.4 lb/t)	342 t/yr (0.27 lb/t)	80	2006		1,840	0.92	Do	9
32	3500 mt/day kiln	3858 t/day	850 mg/ m ³	250 mg/ m ³	70	2004		1,296	1.78		10
33	Model	100	1360 t/yr	270 t/yr	80	1992	6,927,582	6,405		--	1
34	Model	150	2040	410	80	1992	9,384,913	5,751		--	1
35	Kiln				70–90+	2004		1,581–2,109			3

(continued)

Table 12-2. (continued)

No.	Kiln	Prod Rate, t/hr (t/yr)	Uncont. Emission Rate	Cont. Emission Rate	NO _x Reduction (%)	Original Yr of Cost	Annualized Cost (\$)	Cost Effect. (\$/t NO _x)	Cost Burden (\$/t clinker)	Costing Method	Ref.
Selective Catalytic Reduction (SCR) (continued)											
36	Kiln	70 (529,000 t/yr)	800 mg/ m ³	200 mg/ m ³		2004			1.28		18
37	Suwannee American	127 (1,055,000 t/yr)	1320 t/yr (2.5 lb/t)	898 t/yr (1.7 lb/t)	32	2004	9,591,670	22,135	9.11	Similar to OAQPS Cost Man	19
38	Sumter Cement, New Center Hill, FL		2404 t/yr	1460t/yr (1.7 lb/t)	39	2004	10,118,685	10,751	5.88	Similar to OAQPS Cost Man.	20
39	VDZ	1500, 2500, 3500, 5000 t/day				2004			1.28–2.42		5
40	Proposed kiln, CEMEX #3, FL	3850 t/day	3.5 lb/t	1.95 lb/t	44	2005	2,000,000	2,000	1.55	See footnote	17

12.1 REFERENCES

1. U.S. Environmental Protection Agency. *Alternative Control Techniques Document – NO_x Emissions from Cement Manufacturing*. EPA-453/R-94-004. March 1994. Available at www.epa.gov/ttn/cata/dir1/cement.pdf.
2. U.S. Environmental Protection Agency. *NO_x Control Technologies for the Cement Industry*. Prepared by EC/R Incorporated. September 19, 2000. Available at www.epa.gov/ttn/naaqs/ozone/ozonetech/cement_nox_update_09152000.pdf.
3. Midwest Regional Planning Organization. *Interim White Paper – Midwest RPO Candidate Control Measures*. March 2005.
4. CEMBUREAU. *Best Available Techniques for Cement Industry*. December 1999.
5. VDZ (German Cement Works Association). Environmental protection in cement manufacture. *VDZ Activity Report 2003 –2005*. 2005.
6. Suwannee American Cement, Branford, FL. *Best Available Control Technology (BACT) Determination*. Undated.
7. Reduction of NO_x with SNCR Technology at Slite Cement Program, March 2000; and Per Junker, Director of Environmental Protection, County Administration of Gotland, Organization Committee on NO-N2O Emissions Control, November 17, 2000.
8. NESCAUM. *Status Report on NO_x Controls – Technologies and Cost Effectiveness*. December 2000.
9. Texas Commission on Environmental Quality. *Assessment of NO_x Emissions Reduction Strategies for Cement Kilns – Ellis County*. Prepared by ERG Inc. July 14, 2006. Available at www.tceq.state.tx/us/implementation/air/sip/BSA_settle.html.
10. VDZ. *Technical and Scientific Cement Conference. The Present State of NO_x Abatement with the SNCR Process*, Nuremburg, Germany. November 27, 2005.
11. Portland Cement Association. *Report on NO_x Formation and Variability in Portland Cement Kiln Systems Potential Control Techniques and Their Feasibility and Cost Effectiveness*. PCA R&D Serial No. 2227. Prepared by Penta Engineering Corporation. 1999.
12. Holcim. *Project Review of Construction Permit*. Lee Island, MO. May 31, 2002.
13. Letter from Drake Cement to Arizona Department of Environmental Quality. February 25, 2005.
14. Arizona Department of Environmental Quality. *Drake Cement. Class 1 Air Permit Application*. June 9, 2004.

DRAFT – DO NOT QUOTE OR CITE

15. Florida Rock Industries. *SNCR Test Report*. Newberry, FL. December 2004.
16. Hower, J. *Cement Kiln Application of Selective Non-Catalytic Reduction – Myth or Reality?* Presented at IEEE Florida Meeting, May 2002.
17. Florida Department of Environmental Protection. *Report in Support of an Application for a PSD Construction Permit Review – CEMEX, Inc., Kiln 3*. October 12, 2006. Available at www.dep.state.fl.us/Air/permitting/construction/cemex.htm.
18. Linero, A. *SNCR NO_x at US Cement Plants. Is SCR Close Behind?* Paper #638 presented at the AWMA Annual Conference. June 2005.
19. Florida Department of Environmental Protection. *Technical Evaluation and Preliminary Determination – Suwannee American Cement, Branford, FL*. Permit Modification to Increase Production, Inject Fly Ash into Calciner, Install a Selective Non-Catalytic Reduction System. DEP File No. 1210465-011-AC. Division of Air Resources Management. February 16, 2005.
20. Florida Department of Environmental Protection. *BACT Application*. Sumter Cement, New Center Hill, FL. September 2005.

APPENDIX A

BACT/RACT/LAER DETERMINATIONS

Best Available Control Technology (BACT), Reasonably Available Control Technology (RACT), and Lowest Available Emission Rate (LAER) determinations for NO_x emissions for U.S. cement kilns built since 2002 are shown in Table A-1. As noted in the table, a NO_x limit of approximately 2.0 pounds per ton (lb/t) of clinker (30-day rolling average) is a typical emission limit for recently permitted kilns. To achieve this emission limit, plants often install SNCR control technologies, in addition to process controls, such as low NO_x burners and staged combustion. Because they allow the averaging of emissions, emission limits are typically lower for longer compliance periods, such as 30-day compliance periods, than for shorter compliance periods, such as hourly limits. More recent determinations are available at the RACT/BACT/LAER Clearinghouse at <http://cfpub.epa.gov/rblc/htm/bl02.cfm>.

Table A-1. BACT Determinations – U.S. Cement Plants¹⁻³

Permit Date	Plant	Kiln type	Max Production	NO _x Limit (lb/t)	Control Option
2002	Cemex - Victorville, CA	NA	NA	2.8 -30-day rolling avg; 583 lb/hr	LNB, MSC
7/1/02	LaFarge - Buffalo, IA	PH/PC	3,488 t/day	4; 2546 t/yr	GCP
9/24/02	Continental Cement - Hannibal, MO	Kiln	183 t/hr	8	SNCR; LNB; Top air duct
4/10/03	GCC Dakota - Rapid City, SD	Kiln	2,250 t/day	5.5; 2,267 t/yr	PH/PC
6/13/03	Roanoke Cement - Troutville, VA	Kiln	1.3mm TIBS/yr	982 lb/hr; 2,850 t/yr	GCP and CEMS
12/11/03	Lehigh - Mason City, IA	PH/PC	150 t/hr	2.85; 1,496 t/yr	SNCR; LNB; Combustion controls, kiln design
NA	AZ PC - Marana, AZ	5-stage PH/PC	2.3 million t/yr	2.3	GCP, LNB, SC
2/04	Texas Industries - Midlothian, TX	NA	NA	2.8 - 30-day rolling avg; 681 lb/hr	LNB, MSC
6/8/04	Holcim - Lee Island, MO	in-line kiln	4.83 million t/yr	3.0 - first 24 mos; 2.8 after first 24 mo	SC, LNB
				2.4 after first 24 mos	SNCR, SC, LNB
7/05	Florida Rock - Newberry, FL	PH/PC	125 t/hr	1.95 - 30-day rolling average	SNCR-ammonia; Polysius MSC; LNB

(continued)

Table A-1. (continued)

Permit Date	Plant	Kiln type	Max Production	NO _x Limit (lb/t)	Control Option
4/5/05	Titan Cement - Pennsuco, FL	PH/PC	250 t/hr	2.17 – 30-day rolling average	LNB, SC
2/6/06	Sumter Cement – New Center Hill, FL	PH/PC	208 t/hr	1.95; 406 lb/hr - 30-day rolling avg	LNB, SC, SNCR
2/13/06	American Cement – Sumterville, FL	PH/PC	125 t/hr (24-hr rolling)	1.95; 244 lb/hr - 30-day rolling avg	LNB, SC, SNCR
7/7/05	Florida Crushed Stone - Brooksville, FL	PH/PC	125 t/hr	1.95 - 30-day rolling average	same as above
6/9/06	Suwannee American - Branford, FL	PH/PC	127 t/hr	1.95 - 30-day rolling average	same as above
4/12/06	Drake – AZ (Class I area)	PH/PC	83 t/hr	95 lb/hr (hourly rolling 24 hr avg); 1.95 lb/t (daily rolling 30-day average)	same as above

GCP- Good Combustion Practices; LNB - Low NO_x Burners; CEMS - Continuous Emission Monitoring Systems

REFERENCES

1. Arizona Department of Environmental Quality. *Technical Support Document and Statement of Basis for Construction of Drake Cement, L.L.C., Portland Cement Plant*. Air Quality Permit Number 1001770. June 9, 2004. Available at www.azdeq.gov/download/draketsd.pdf. Accessed March 6, 2007.
2. Florida Department of Environmental Protection. *Report in Support of an Application for a PSD Construction Permit Review – Natural Resources of Central Florida, Inc.* American Cement Company, Sumterville, FL. October 4, 2005. pp. 93–99. Available at www.dep.state.fl.us/Air/permitting/construction/american.
3. Florida Department of Environmental Protection. *Technical Determination*. Sumter Cement Company. December 21, 2005.